



Fluid Power Specialist
Since 1948

LOGIC POPPET VALVES AND CARTRIDGE MANIFOLD SYSTEMS

Copyright ©2026, Almo Manifold & Tool Co. All rights reserved.

All attempts have been made to make the information in this document complete and accurate. Almo Manifold & Tool Co. will in no event be liable for any special or consequential damages whatsoever including, but not limited to, loss of business, profits, production, or for any personal or bodily injury, including death resulting there from, which may be incurred by the buyer, its agent or employees by virtue of defective material or workmanship in any article or material supplied by Almo. The specification contained in this document are subject to change without notice.

VERSION 25.0

RETURN POLICY

All returns must be made within 90 days of purchase. A 20% restock charge will be assessed on all items approved for return in stock. A return authorization number will be required for all items returned and return freight will be prepaid by the customer. All items must be in new/undamaged condition for resale in order to obtain credit. All items returned will be for product credit only.

NO REUNDS, CASH, OR CHECK WILL BE ISSUED.

Mailing Address: P.O. Box 112, East Tawas, MI 48730
Shipping Address: 777 Aulerich Road, East Tawas, MI 48730
Email: sales@almomanifold.com, info@almomanifold.com

Visit us on the web at www.almomanifold.com

Toll Free: (877) ALMO.NOW
Tel: (989) 984.0800
Fax : (989) 984.0830

TABLE OF CONTENTS

	PAGE
Contents	
INSERTS	5
DIN 24342 Logic Poppet Valve.....	6
COVERS	9
Directional Control	10
Poppet Check Cover (AMT-PCC-**-C).....	10
Pilot-Operated Check Cover (AMT-POCC-**).	12
Dump Valve or On/Off Valve with D03/D05 Interface (AMT-PDBASH-**).....	14
Poppet Cover with D03 Interface (AMT-PDD03-**)	18
Poppet Cover with Directional Control Interface & Shuttle Function Version #2 (AMT-PDSH2-**).....	20
Poppet Cover with Directional Control Interface & Shuttle Function Version #3 (AMT-PDSH3-**).....	22
Poppet Cover with Directional Control Interface & Shuttle Function Version #5 (AMT-PDSH5-**).....	24
Pressure Control	26
Poppet Relief Cover with Standard Relief Function (AMT-PRC-**-S).....	26
Poppet Relief Cover with Solenoid Loading/Venting Relief Function (AMT-PRC-**-L)	28
D03 Relief Sandwich Accessory (AMT-D03-Relief-**)	30
Flow Control	32
Poppet Stroke Cover (AMT-PSTK-**)	32
Poppet Stroke Cover with D03 Interface (AMT-PSTK-**-D03).....	34
Poppet Stroke Cover with D03 Interface on Y Side (AMT-PSTKY-**-D03)	36
Poppet Stroke Cover with Limiter Hidden (AMT-PSLSH-**)	38
ACTIVE POPPETS	41
DIN 24342 Active Poppet & Cover (AMT-ACT-**).....	42
DIN 24342 Active Poppet & Cover with D03 Interface (AMT-ACTD03-**).....	44
DIN 24342 Active Poppet & Stroke Limiting Cover with D03 Interface (AMT-ACTD03-PSTK-**)	44
DIN 34342 Active Poppet & Cover with Limit Switch (AMT-MAP-**)	48
COUNTERBALANCE VALVES	51
<u>(Available with or without inline cavity block)</u>	



PROPORTIONAL FLOW CONTROL VALVE 57

DIN 34342 Proportional Flow Control (AMT-PFC-**-**)... 58

SINGLE DIN CAVITY BLOCKS..... 65

UCB Blocks (AMT-UCB-**-D)..... 66

80 mm DIN Block (AMT-CB-80-*-D)..... 68

HIGH-LOW WITH REGEN MANIFOLD ASSEMBLY 71

PILOT-OPERATED DIRECTIONAL CONTROL VALVE CIRCUITS 75

Directional Circuit/Regen 76

Pump Circuit 77

LARGE SPOOL VALVE REPLACEMENTS 79

Directional Control 80

Pressure Control..... 81

90-DEGREE FLANGE VALVES 83

Check Valve (AMT-9-***-CK)..... 84

Pilot-Operated Check Valve (AMT-9-***-PC-ED) 86

Dump Valve (AMT-9-***-DV-**) 88

Bi-Directional Valve (AMT-9-***-BD-ED) 90

Relief Valve (AMT-9-***-RV-**)..... 92

Load Relief Valve (AMT-9-***-LR-**) 94

Volume Control Valve (AMT-9-***-VC)..... 96

ORIFICES..... 98

TECHNICAL INFORMATION..... 100

NOTES:

INSERTS

DIN 24342 SLIP-IN LOGIC CARTRIDGE VALVES/INSERTS

SIZES 16 mm TO 80 mm

6000 PSI



- ✓ Compatible with standard DIN 24342 cavities
- ✓ Sizes 16 mm thru 80 mm
- ✓ Two different area ratios available
- ✓ Dampening nose option
- ✓ Four spring pressures available
- ✓ Close fit tolerance between poppet & sleeve
- ✓ Excellent pressure-drop characteristics
- ✓ Nose removable orifice option
- ✓ Zero leak between A & B above 500 psi.
- ✓ "Z" seal option: zero leak between AP & A-B side
- ✓ "Z" seal recommended when used with PRC covers

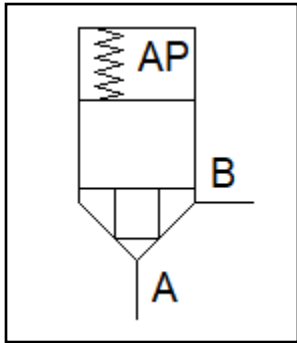

1.6:1 AP:A area ratio

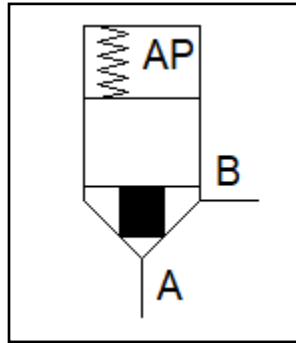

1.6:1 ratio w/dampening

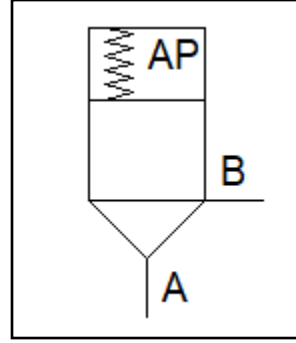

1:1 AP:A ratio

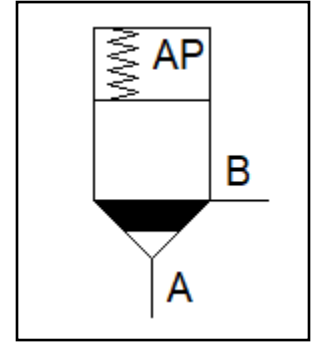

1:1 ratio w/dampening

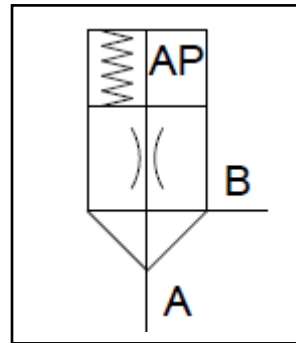

1:1 AP:A ratio w/orifice

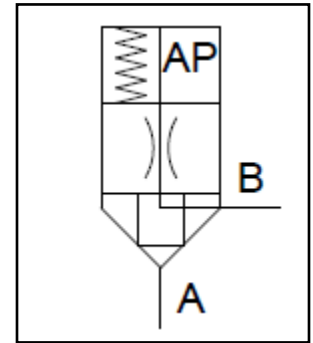

1:1.6 AP:B ratio w/orifice

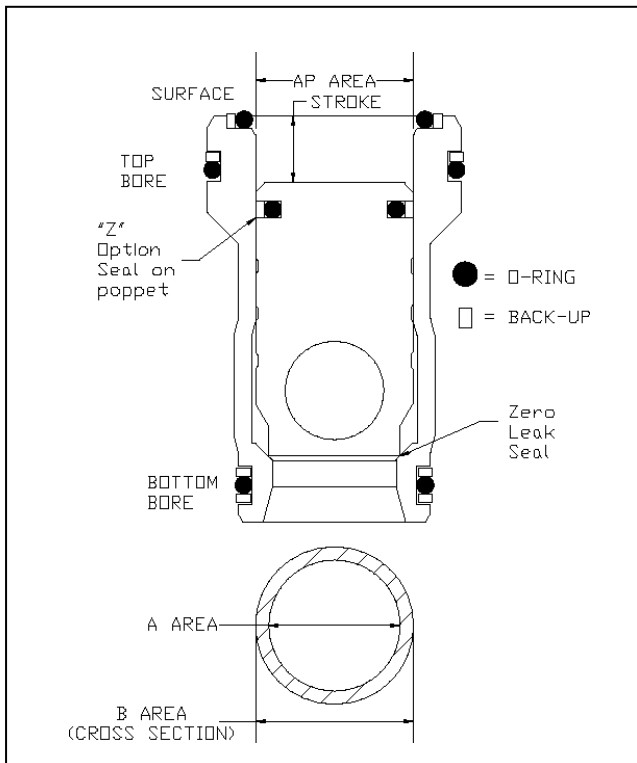

FORCE BALANCE: (Force = Pressure*Area)

$$P_{AP} * A_{AP} + \text{SpringForce} = P_A * A_A + P_B * A_B$$

Valve is open if:

$$P_{AP} * A_{AP} + \text{SpringForce} < P_A * A_A + P_B * A_B$$

Valve is closed if:

$$P_{AP} * A_{AP} + \text{SpringForce} > P_A * A_A + P_B * A_B$$

Performance Curves

Pressure Drop vs. Flow Rate for LCV-16, LCV-25, LCV-32 & LCV-40
W/O Dampening, Viscosity = 225 SUS @ 100 F, T= 100 F

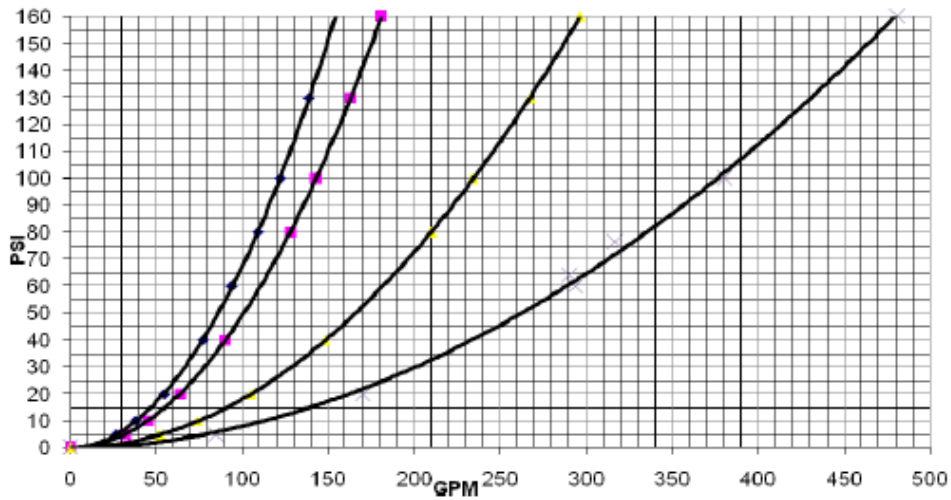

Pressure Drop vs. Flow Rate for LCV-50, LCV-63, & LCV-80
W/O Dampening, Viscosity = 225 SUS @ 100°F, T= 100°F

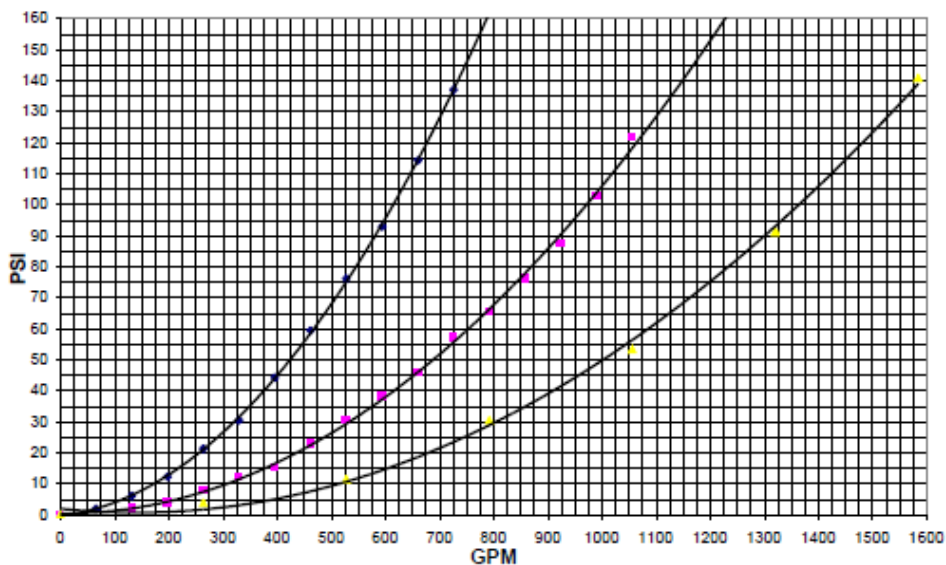

Pressure drops for Dampening Valves are on average 60% higher than flows shown.

Order Code

AMT-LCV--**-D-**-**-***

Almo
Manifold
& Tool

Logic Cartridge Valve

Spring Cracking Pressure:
5, 15, 30, or 60 psi

Size: **16, 25, 32, 40, 50, 63, 80** mm

Blank = no orifice
Z = zero leak seal on poppet
OA = with orifice AP to A
OB = with orifice AP to B

1.6 = 1.6:1 AP:A area ratio
1 = 1:1 AP:A area ratio

Blank = no dampening nose
D = dampening nose

Blank = Viton O-rings
B = Buna 90 O-rings

NOTES:

COVERS

DIN 24342 COVER FOR DIRECTIONAL CONTROL

SIZES 16 mm TO 80 mm

6000 PSI

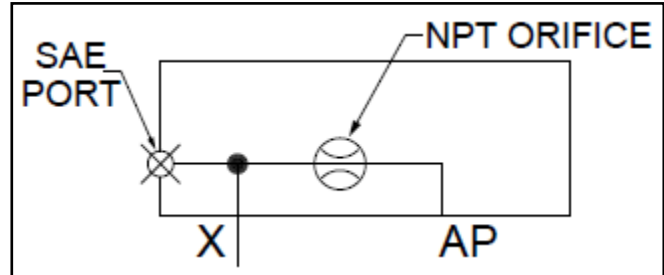

- ✓ Removable NPT orifice plug
- ✓ SAE O-ring port for access to NPT orifice, gauging, or remote piloting

Applications

Check Valve

Allows free-flow from A to B & provides check function from B to A by connecting the X pilot to the B port of the logic valve.

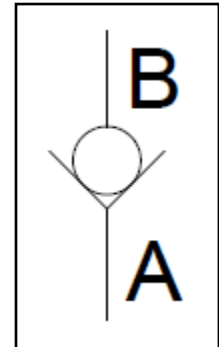
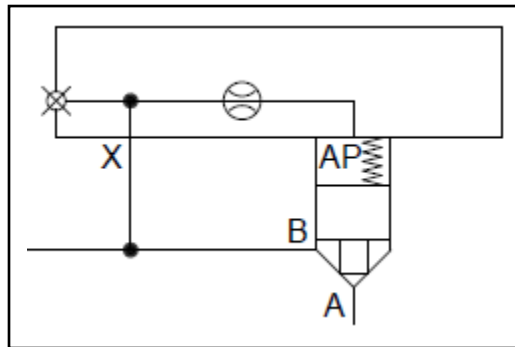

Manual/External Piloting

By not connecting the X pilot internally, a separate pilot pressure can be used via the SAE port to manually hold the valve closed. Pilot pressure & spring forces act to close the valve, & forces at A & B act to open the valve.

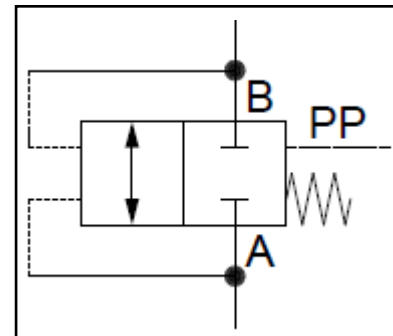
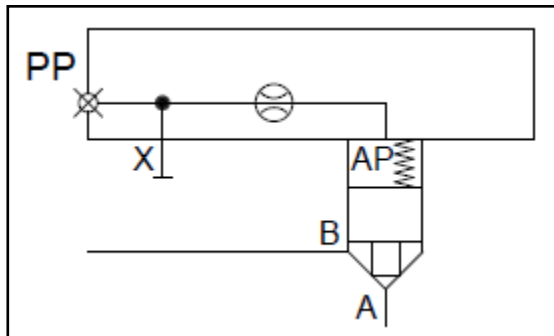

General Layout

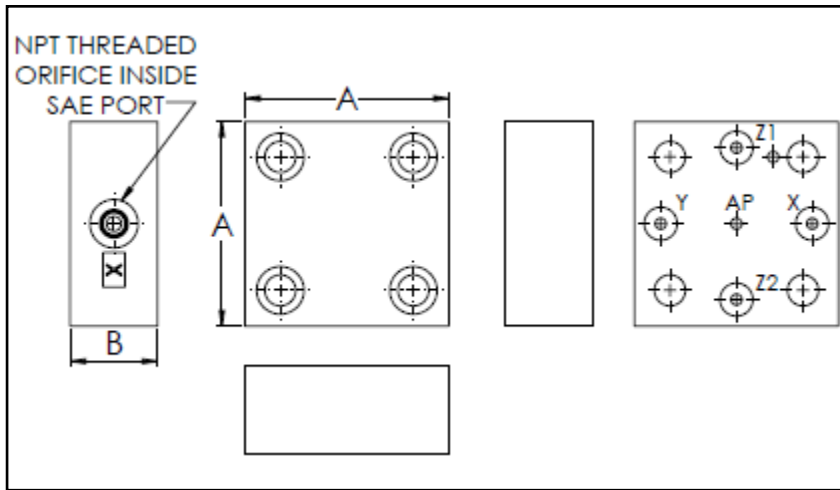

Sizes 16 mm to 63 mm

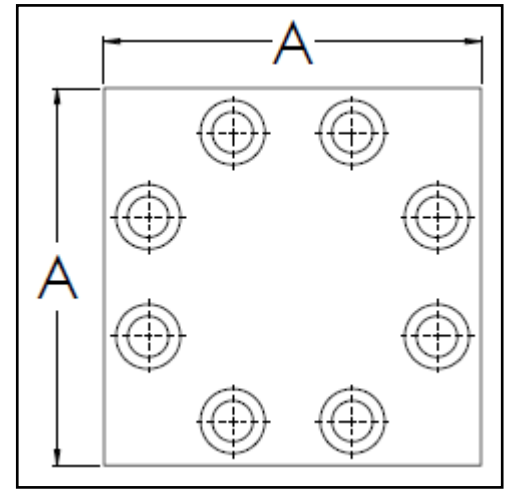

80 mm "top" face shown above

Cover Size	A	B	Port Size	Orifice		Bolts
				Threads	Size	
16 mm	2.75"	1.40"	SAE#4	1/16-27 NPT	1.0 mm	5/16-18 X 1.50" (4)
25 mm	3.50"	1.50"	SAE#4	1/16-27 NPT	1.2 mm	1/2-13 X 1.50" (4)
32 mm	4.00"	2.00"	SAE#4	1/16-27 NPT	1.3 mm	5/8-11 X 2.00" (4)
40 mm	5.00"	2.40"	SAE#4	1/16-27 NPT	1.5 mm	3/4-10 X 2.50" (4)
50 mm	5.55"	2.75"	SAE#4	1/16-27 NPT	1.8 mm	3/4-10 X 3.00" (4)
63 mm	7.00"	3.38"	SAE#6	1/8-27 NPT	2.0 mm	1-1/4-7 X 3.50" (4)
80 mm	9.50"	3.50"	SAE#6	1/8-27 NPT	2.5 mm	1-8 X 4.00" (8)

Order Code

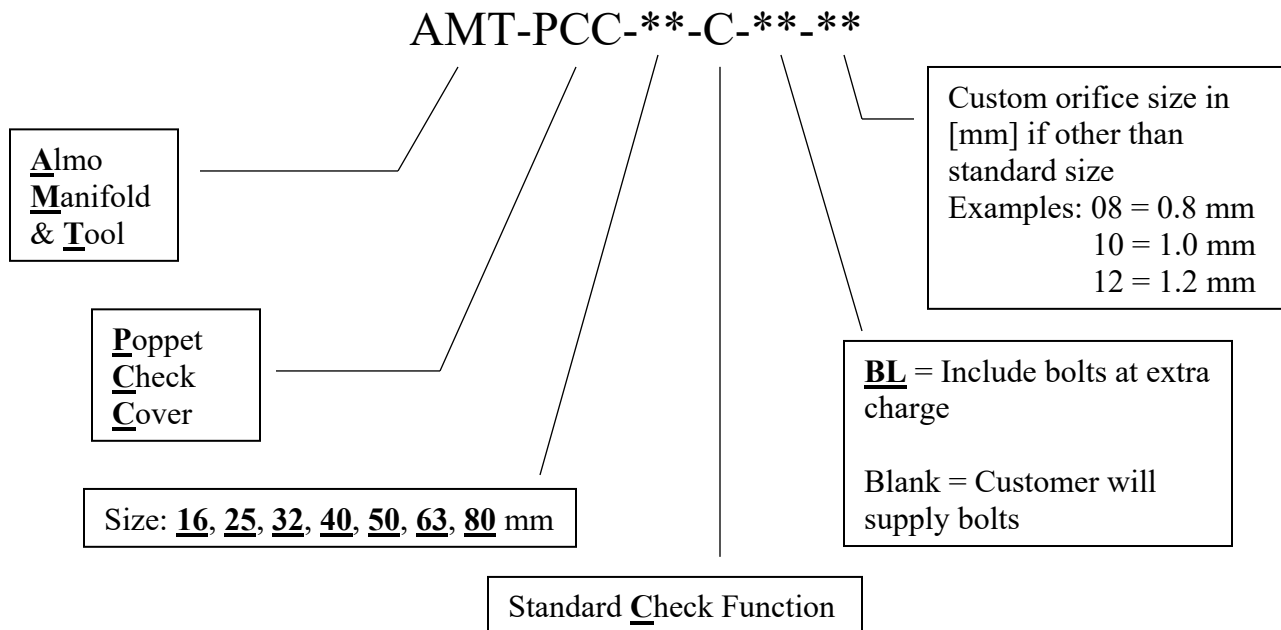

DIN 24342 COVER FOR DIRECTIONAL CONTROL

SIZES 16 mm TO 80 mm

6000 PSI

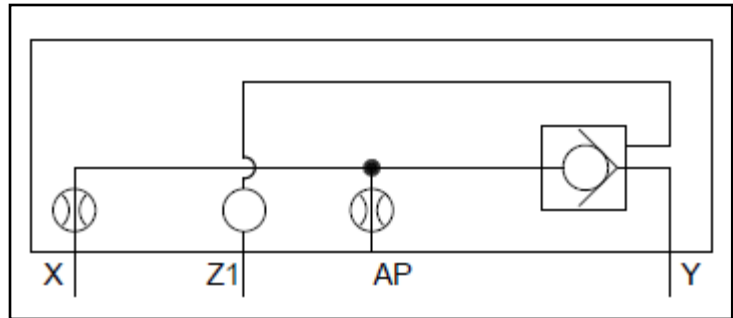

- ✓ Removable orifice plugs
- ✓ 3 to 1 pilot ratio

Applications

Pilot-Operated Check Valve

Allows free flow from A to B & provides the check function from B to A by connecting the X pilot to the B port of the logic valve.

To achieve bi-directional flow, just supply Z1 with pilot pressure.

The pilot ratio is 3 to 1.

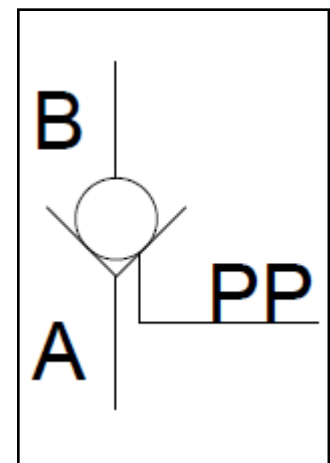
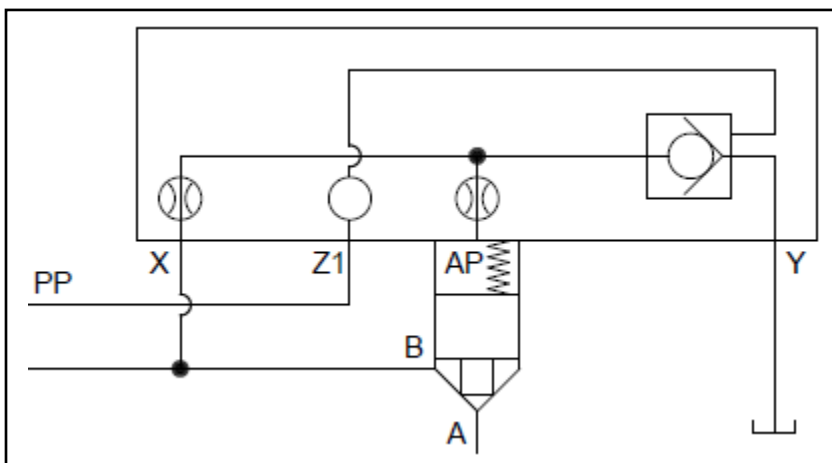
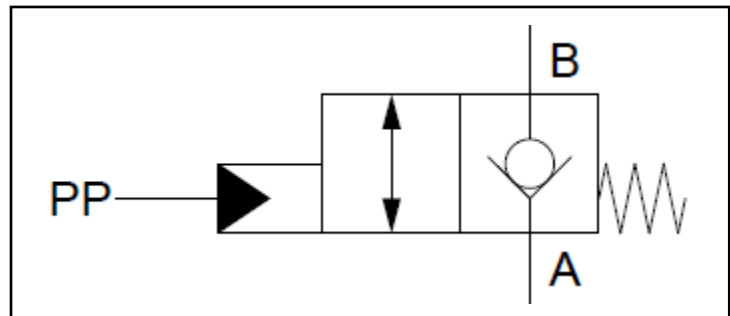

General Layout

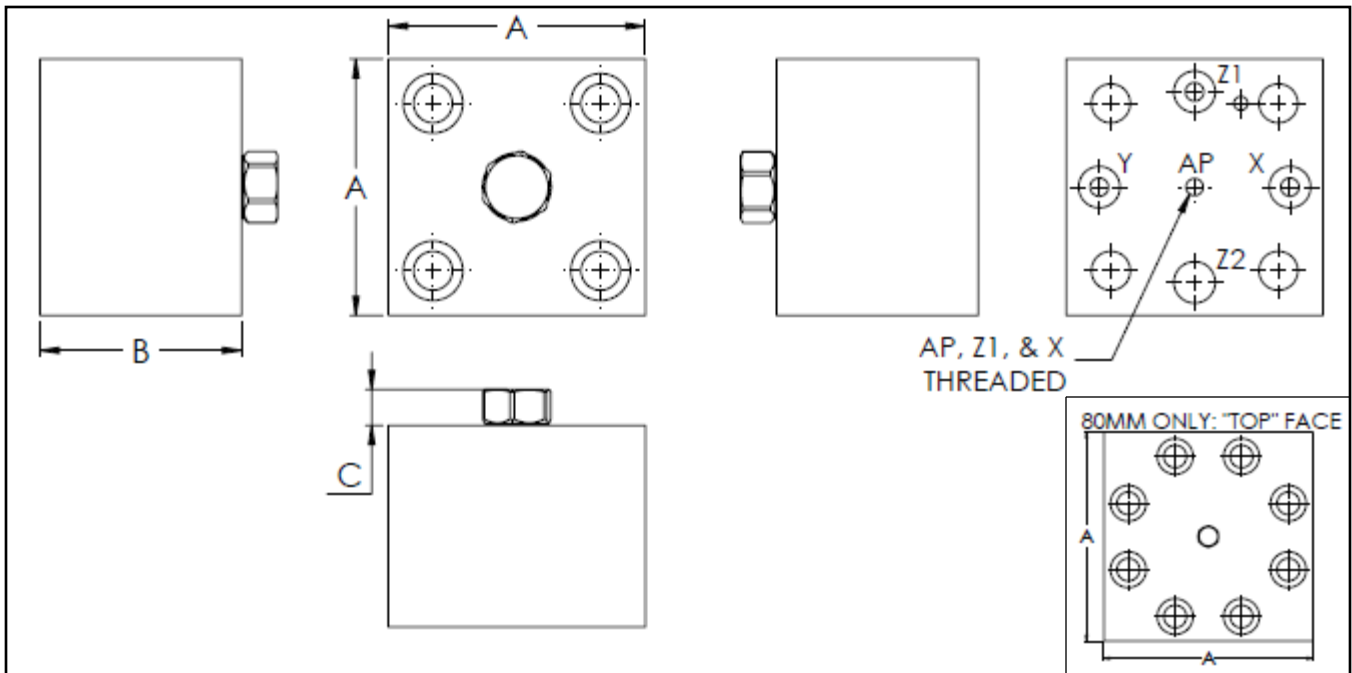

Sizes 16 mm to 63 mm (80 mm "top" face shown in bottom right corner)

Cover Size	A	B	C	Threads	Orifice Size		Bolts
					X	AP	
16 mm	2.75"	2.75"	0.50"	1/4-20 UNC (X, Z1) 1/16-27 NPT (AP)	1.0 mm	1.2 mm	5/16-18 X 2.50" (4)
25 mm	3.50"	2.75"	0.50"	1/16-27 NPT	1.0 mm	1.2 mm	1/2-13 X 2.75" (4)
32 mm	4.00"	2.75"	0.50"	1/16-27 NPT	1.2 mm	1.3 mm	5/8-11 X 2.50" (4)
40 mm	5.00"	2.75"	0.50"	1/16-27 NPT	1.3 mm	1.5 mm	3/4-10 X 2.75" (4)
50 mm	5.55"	2.75"	0.50"	1/16-27 NPT	1.5 mm	1.8 mm	3/4-10 X 3.00" (4)
63 mm	7.00"	3.38"	0.50"	1/16-27 NPT	1.8 mm	2.0 mm	1-1/4-7 X 3.50" (4)
80 mm	9.50"	3.50"	0.50"	1/8-27 NPT	2.0 mm	2.8 mm	1-8 X 4.00" (8)

Order Code

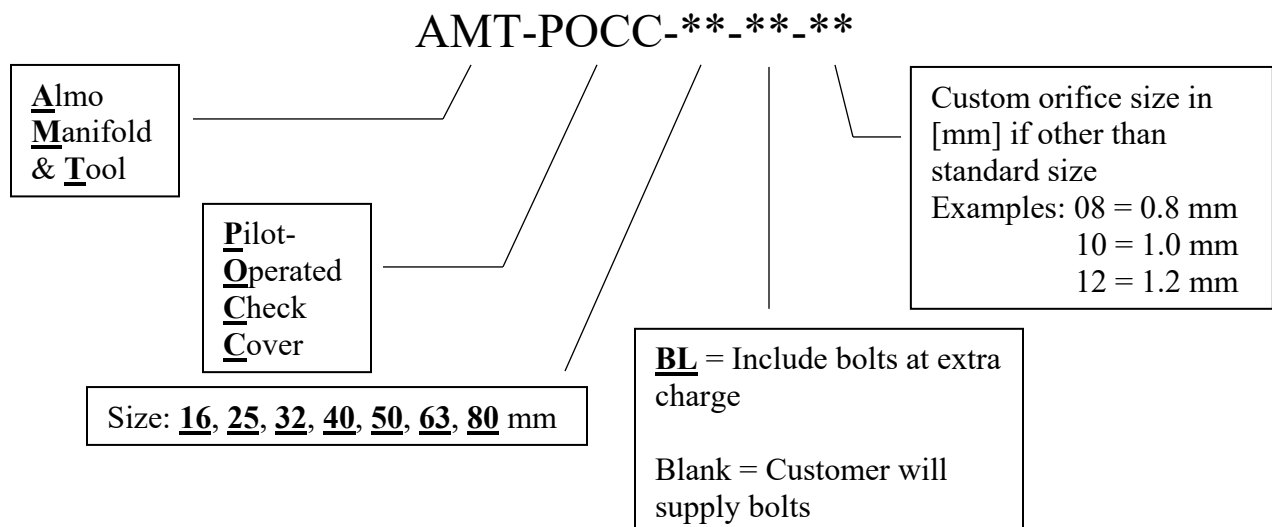

DIN 24342 COVER FOR DIRECTIONAL CONTROL

SIZES 16 mm TO 40 mm

6000 PSI

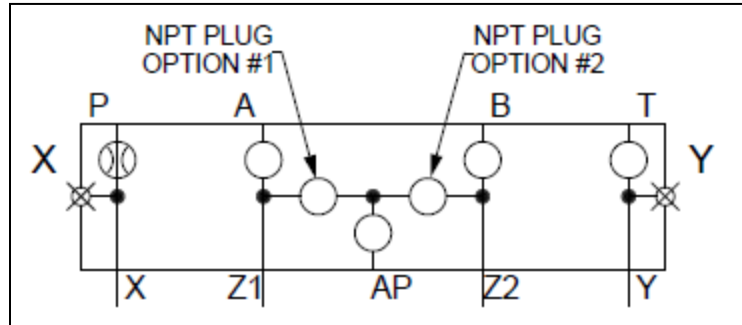
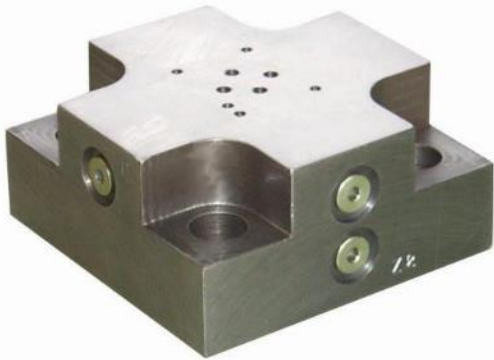

Plug Option #1

Plug Option #2

- ✓ Standard D03 interface (ISO 4401-AB-03-4A NFPA-D03)
- ✓ SAE #4 O-ring ports for external access to X & Y
- ✓ Removable orifice plug options
- ✓ Ships standard as plug option #1

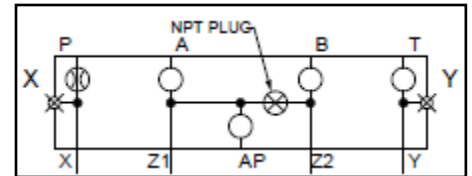
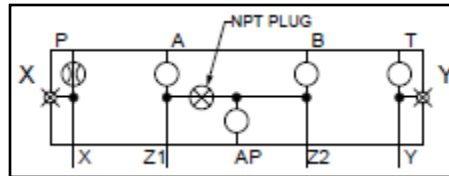

Applications

Dump Valve or On/Off Valve

Can be used as a dump valve by connecting X to the B port (side of the logic valve) & connecting Y to drain. The images below show the two different plug options. Plug option #1 will allow the valve to dump in the de-energized state. Plug option #2 will allow the valve to dump in the energized state.

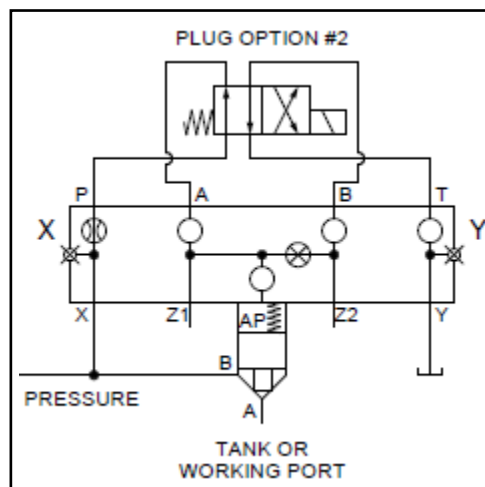
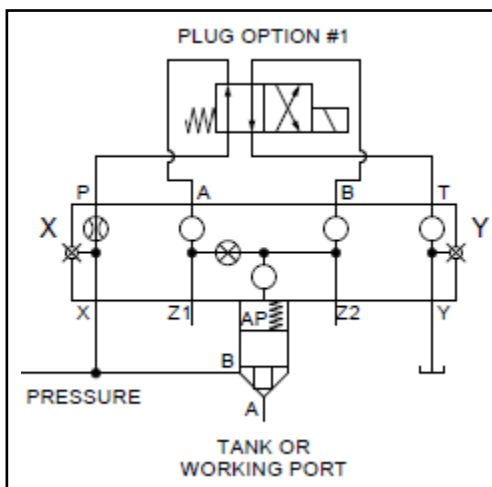
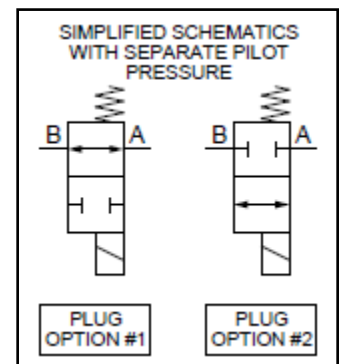
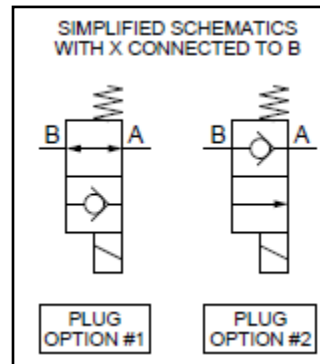

Note: If port A is connected to a working port, then connecting X to the B port, as shown to the left, does not prevent pressure at A from overcoming the forces acting to keep the valve closed. Flow could occur from A to B. To prevent this, use a separate pilot pressure for X.

General Layout

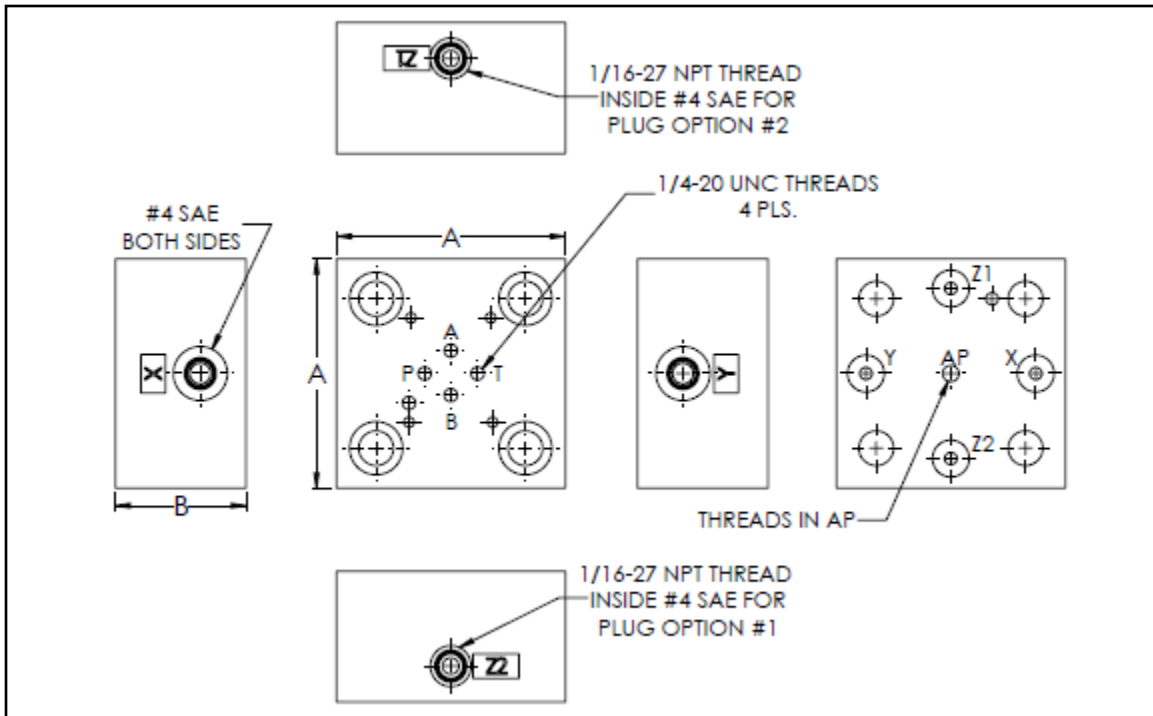

Sizes 16 mm to 40 mm

Cover Size	A	B	Threads in AP	*Orifice Size in P	Interface	Bolts
16 mm	2.75"	1.50"	1/16-27 NPT	1.0 mm	D03	5/16-18 X 1.50" (4)
25 mm	3.50"	2.00"	1/16-27 NPT	1.2 mm	D03	1/2-13 X 2.00" (4)
32 mm	4.00"	2.00"	1/16-27 NPT	1.3 mm	D03	5/8-11 X 2.00" (4)
40 mm	5.00"	2.40"	1/16-27 NPT	1.5 mm	D03	3/4-10 X 2.50" (4)

*Only one orifice installed in P port of D03 interface. Other orifices are optional.

Order Code

AMT-PDBASH-**-*_**_**

Almo
Manifold
& Tool

Poppet cover with
Directional control interface.
Basic cover design
H style configuration

Size: 16, 25, 32, 40 mm

Blank = Plug option #1 (Standard)
2 = Plug option #2

Custom orifice size in
[mm] if other than
standard size
Examples: 08 = 0.8 mm
10 = 1.0 mm
12 = 1.2 mm

BL = Include bolts at extra
charge

Blank = Customer will
supply bolts

DIN 24342 COVER FOR DIRECTIONAL CONTROL

SIZES 50 mm TO 80 mm

6000 PSI

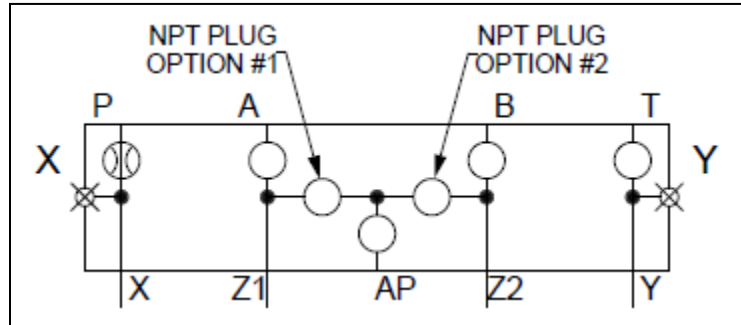
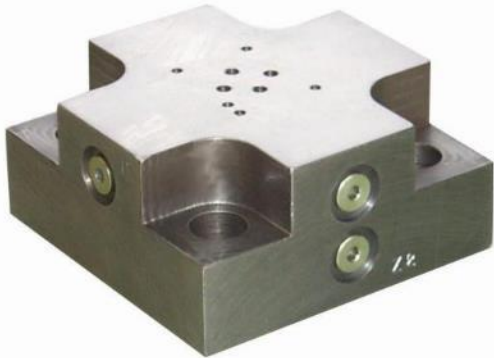

Plug Option #1

Plug Option #2

- ✓ Standard D05 interface, optional D03 (ISO 4401-03-02-0-94) (ISO 4401-05-04-0-94)
- ✓ SAE #4 O-ring ports for external access to X & Y
- ✓ Removable orifice plug options
- ✓ Ships standard as plug option #1

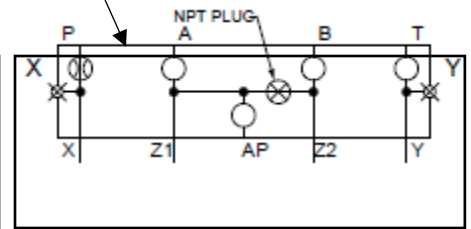
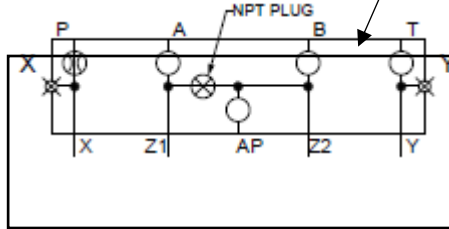

Applications

Dump Valve or On/Off Valve

Can be used as a dump valve by connecting X to the B port (side of the logic valve) & connecting Y to drain. The images below show the two different plug options. Plug option #1 will allow the valve to dump in the de-energized state. Plug option #2 will allow the valve to dump in the energized state.

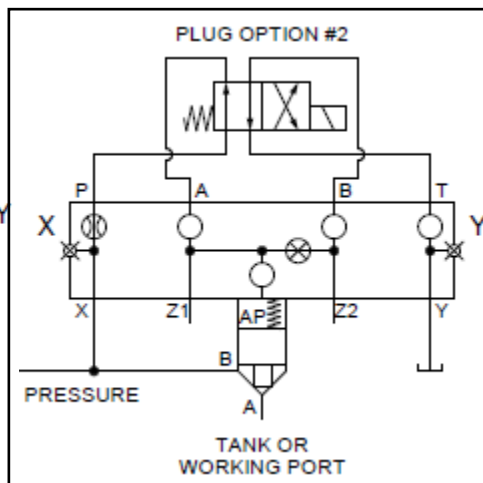
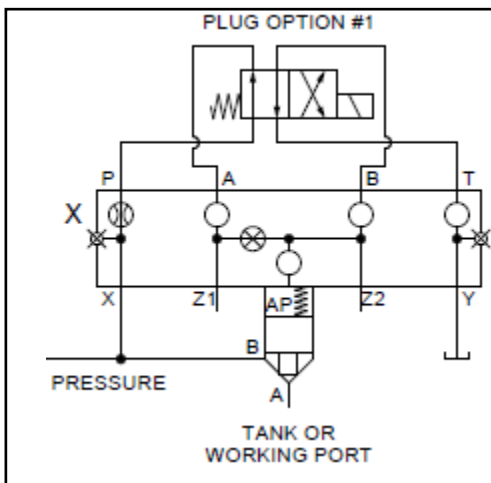
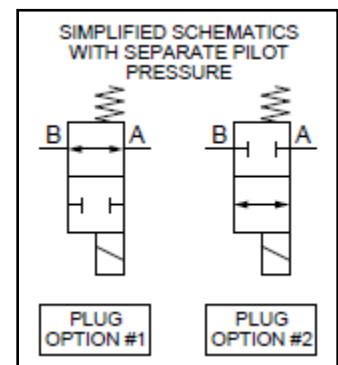
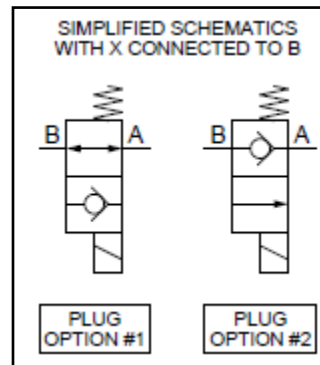

Note: If port A is connected to a working port, then connecting X to the B port, as shown to the left, does not prevent pressure at A from overcoming the forces acting to keep the valve closed. Flow could occur from A to B. To prevent this, use a separate pilot pressure for X.

General Layout

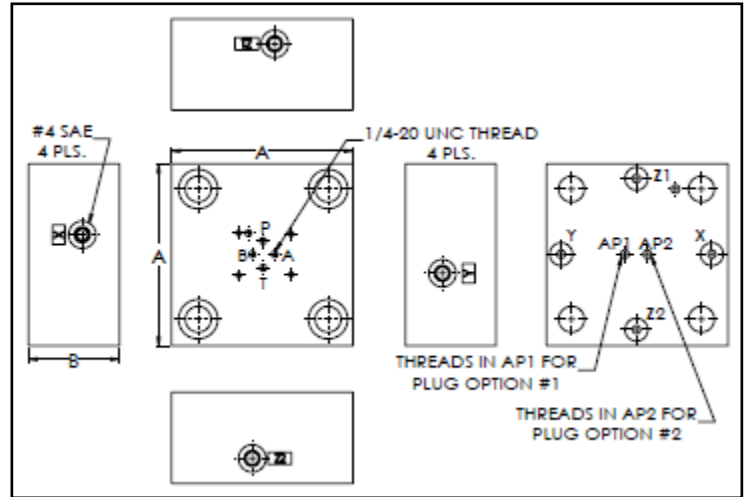
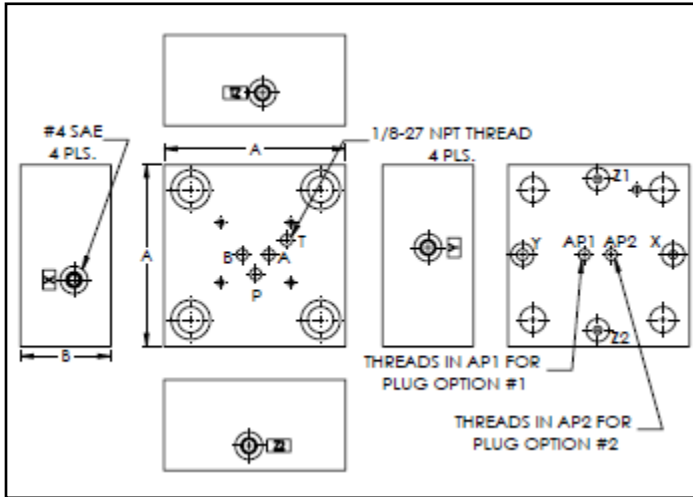

Standard D05 interface layout (80 mm not shown)

Optional D03 interface (80 mm not shown)

Cover Size	A	B	Threads in AP1 & AP2	*Orifice Size in P	Standard Interface	Bolts
50 mm	5.55"	2.75"	1/8-27 NPT	1.8 mm	D05	3/4-10 X 3.00" (4)
63 mm	7.00"	3.38"	1/8-27 NPT	2.0 mm	D05	1-1/4-7 X 3.50" (4)
80 mm	9.50"	3.50"	1/8-27 NPT	2.5 mm	D05	1-8 X 4.00" (8)

*Chart for Standard D05 interface. D03 interface optional.

**Optional D03 interface uses 1/4-20 UNC orifice in P. Orifice sizes are the same for D03 & D05.

***Only one orifice installed in P port of D03/D05 interface. Other orifices are optional.

Order Code

AMT-PDBASH-**-**_*_*_**_*_*_**_*_*_**

Almo
Manifold
& **T**ool

Poppet cover with
Directional control interface.
Basic cover design
H style configuration

Size: **50**, **63**, or **80** mm

Directional Control Interface:
Blank = Standard D05
3 = Optional D03 interface

Custom orifice size in [mm] if other than standard size
Examples: 08 = 0.8 mm
10 = 1.0 mm
12 = 1.2 mm

BL = Include bolts at extra charge

Blank = Customer will supply bolts

Blank = Plug option #1 (Standard)
2 = Plug option #2

DIN 24342 COVER FOR DIRECTIONAL CONTROL

SIZES 16 mm TO 40 mm

6000 PSI

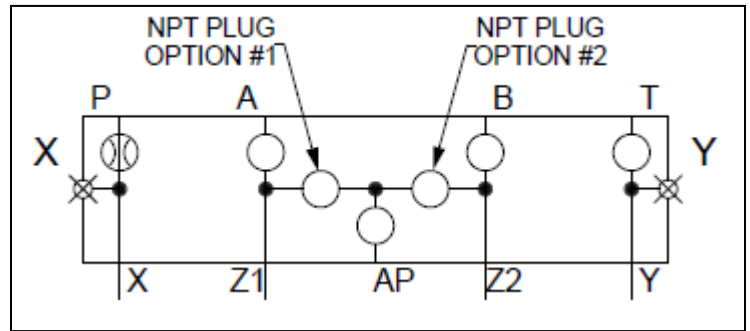
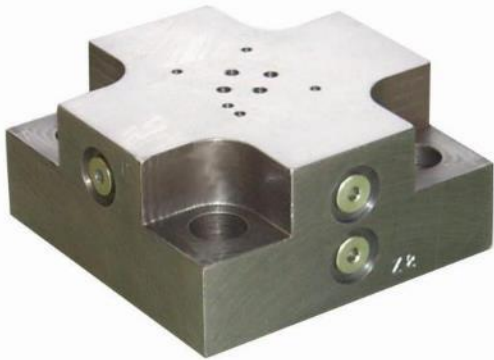

Plug Option #1

Plug Option #2

- ✓ Same as the PDBASH cover but has D03 rotated 90° to match industry standard
- ✓ (ISO 4401-03-02-0-94)
- ✓ SAE #4 O-ring ports for external access to X & Y
- ✓ Removable orifice plug options
- ✓ Ships standard as plug option #1

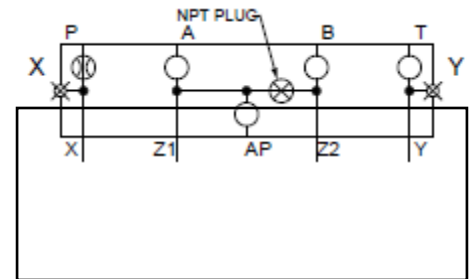
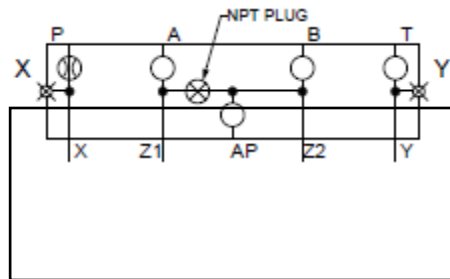

Applications

Dump Valve or On/Off Valve

Can be used as a dump valve by connecting X to the B port (side of the logic valve) & connecting Y to drain. The images below show the two different plug options. Plug option #1 will allow the valve to dump in the de-energized state. Plug option #2 will allow the valve to dump in the energized state.

Note: If port A is connected to a working port, then connecting X to the B port, as shown to the left, does not prevent pressure at A from overcoming the forces acting to keep the valve closed. Flow could occur from A to B.

To prevent this, use a separate pilot pressure for X.

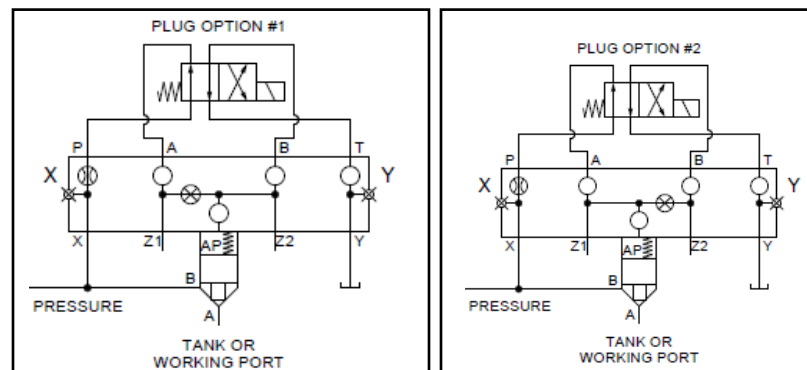
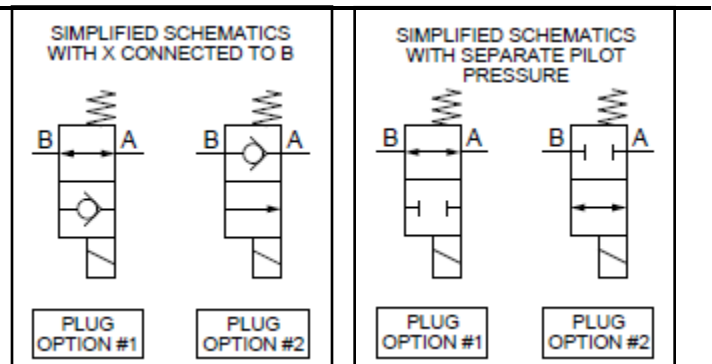

General Layout

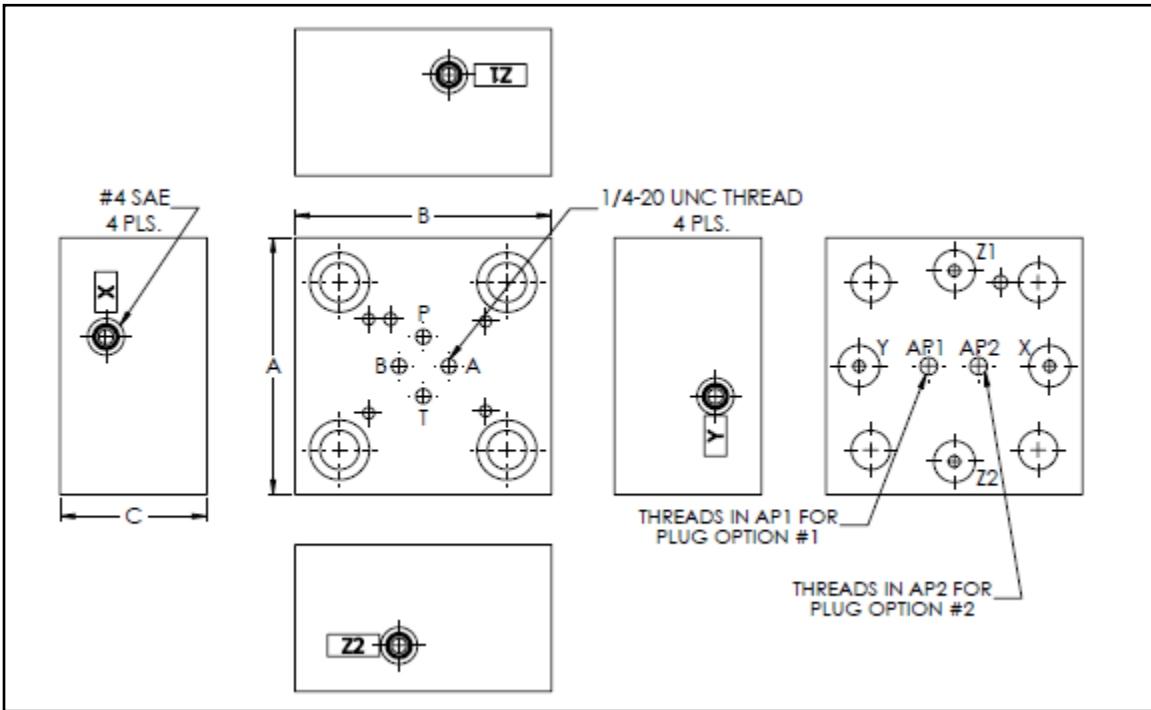

Sizes 16 mm to 40 mm

Cover Size	A	B	C	Threads in AP	*Orifice Size in P	Interface	Bolts
16 mm	2.75"	3.00"	1.50"	1/16-27 NPT	1.0 mm	D03	5/16-18 X 1.50" (4)
25 mm	3.50"	3.50"	2.00"	1/16-27 NPT	1.2 mm	D03	1/2-13 X 2.00" (4)
32 mm	4.00"	4.00"	2.00"	1/16-27 NPT	1.3 mm	D03	5/8-11 X 2.00" (4)
40 mm	5.00"	5.00"	2.40"	1/16-27 NPT	1.5 mm	D03	3/4-10 X 2.50" (4)

*Only one orifice installed in P port of D03 interface. Other orifices are optional.

Order Code _____

AMT-PDD03-**-*_**_**

Almo
Manifold
& **T**ool

Poppet cover with
Directional control interface.
D03 valve pattern

Size: **16, 25, 32, 40** mm

Blank = Plug option #1 (Standard)
2 = Plug option #2

Custom orifice size in
[mm] if other than
standard size
Examples: 08 = 0.8 mm
10 = 1.0 mm
12 = 1.2 mm

BL = Include bolts at extra
charge
Blank = Customer will
supply bolts

DIN 24342 COVER FOR DIRECTIONAL CONTROL

SIZES 16 mm TO 80 mm

6000 PSI

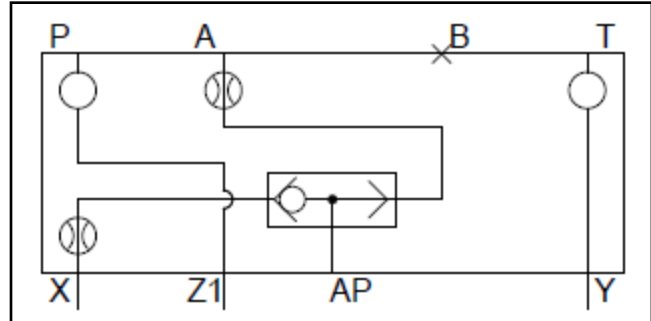

- ✓ Shuttle valve senses the greater of two pressures
- ✓ 16 mm thru 63 mm: Standard D03 interface (ISO 4401-03-02-0-94)
- ✓ 80 mm: Standard D05 interface (ISO 4401-05-04-0-94)
- ✓ Standard orifice installed in A port of D03 pattern & X port
- ✓ Removable orifice plug options

Applications

On/Off Check Valve

Will hold valve closed in one condition and serve as a check valve in the other condition.

Senses the greater of two pressures between the X port & the A port. The X port should be connected to the B port (side of the logic valve), & the Z1 port should be connected to the A port (nose of the logic valve).

By using a standard D03 directional control with flow from P to A in the de-energized condition, the shuttle will use the greater pressure to hold the valve closed. Energizing the solenoid prevents the shuttle from sensing the Z1 pilot, thereby establishing free flow from A to B & a check valve function from B to A.

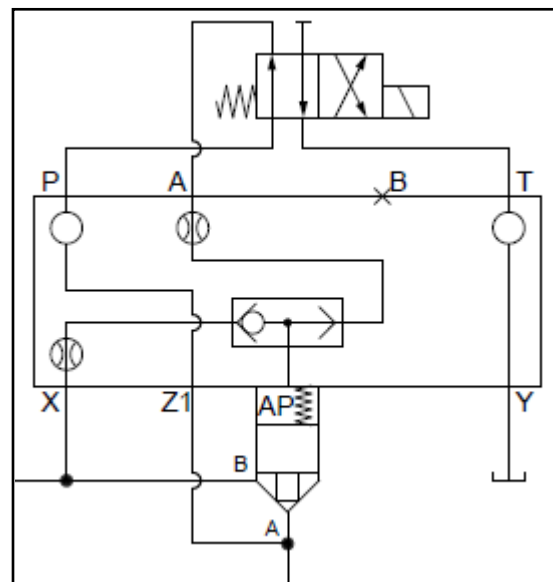
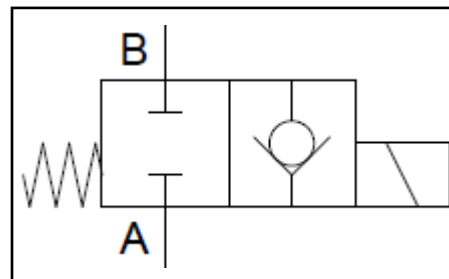

General Layout

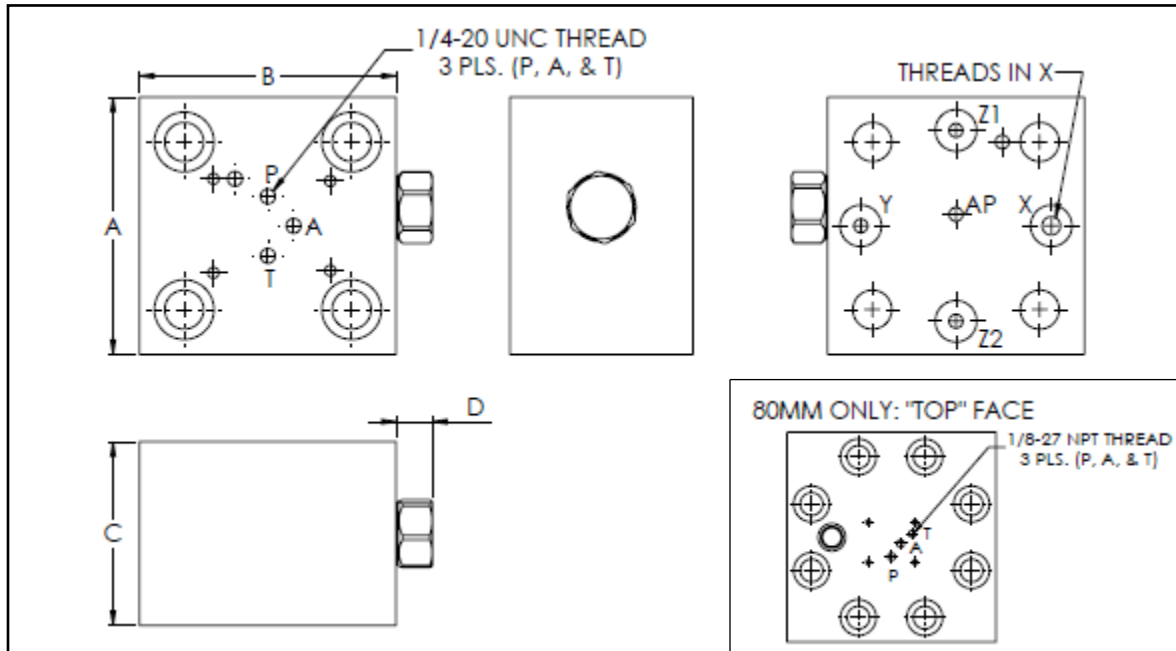

Sizes 16 mm to 63 mm (80 mm "top" face shown in bottom right corner)

Cover Size	A	B	C	D	Threads in X	Orifice Size		Bolts
						A	X	
16 mm	2.75"	3.00"	3.00"	0.51"	1/4-20 UNC	1.0 mm	1.0 mm	5/16-18 X 3.00" (4)
25 mm	3.50"	3.50"	2.50"	0.51"	1/16-27 NPT	1.2 mm	1.2 mm	1/2-13 X 2.50" (4)
32 mm	4.00"	4.00"	2.00"	0.51"	1/16-27 NPT	1.3 mm	1.3 mm	5/8-11 X 2.00" (4)
40 mm	5.00"	5.00"	2.40"	0.51"	1/16-27 NPT	1.5 mm	1.5 mm	3/4-10 X 2.50" (4)
50 mm	5.55"	5.55"	2.75"	0.51"	1/16-27 NPT	1.8 mm	1.8 mm	3/4-10 X 3.00" (4)
63 mm	7.00"	7.00"	3.38"	0.51"	1/16-27 NPT	2.0 mm	2.0 mm	1-1/4-7 X 3.50" (4)
80 mm	9.50"	9.50"	3.75"	0.00"	1/8-27 NPT	2.5 mm	2.5 mm	1-8 X 4.00" (8)

Order Code

AMT-PDSH2-**-**-**

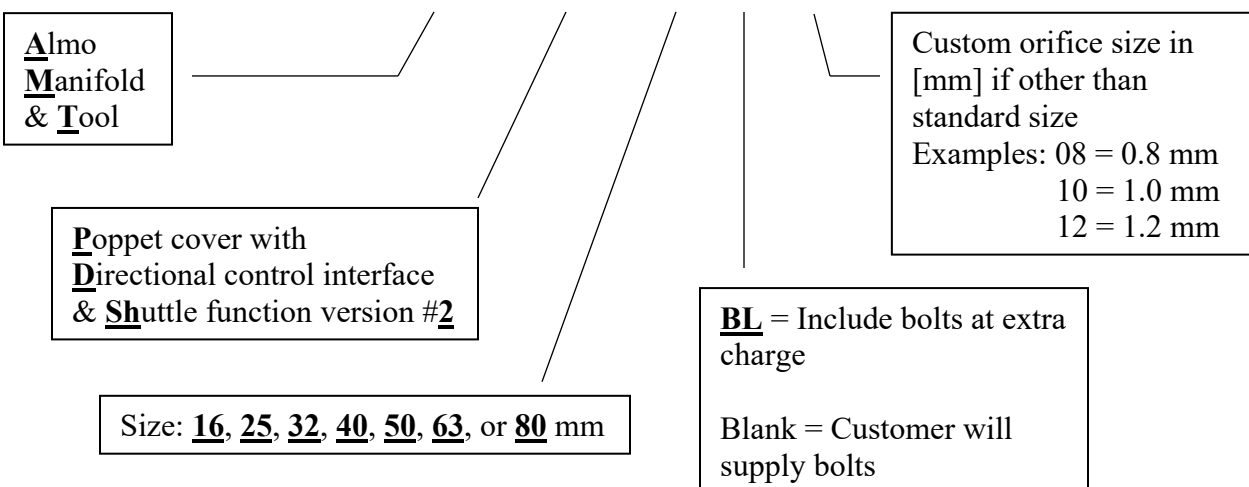

DIN 24342 COVER FOR DIRECTIONAL CONTROL

SIZES 40 mm TO 80 mm

6000 PSI

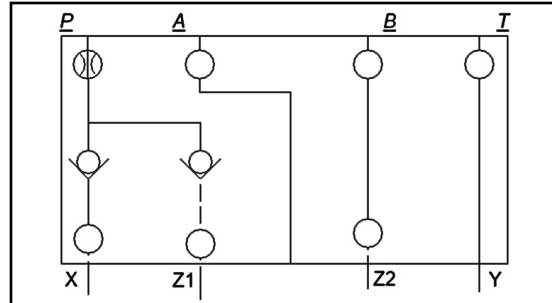
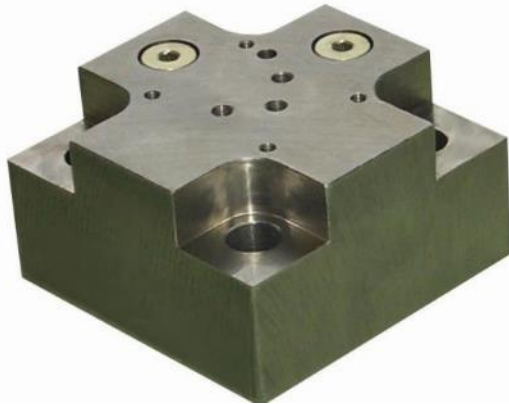

- ✓ 2 check valves senses the greater of two pressures
- ✓ 40 mm thru 50 mm: Standard D03 interface (ISO 4401-03-02-0-94)
- ✓ 63 mm thru 80 mm: Standard D05 interface (ISO 4401-05-04-0-94)
- ✓ Standard orifice installed in P
- ✓ Removable orifice plug options

Applications

On/Off Valve

Will hold valve closed in one condition & will allow valve to open in the other condition.

Senses the greater of two pressures between the X port & the Z1 port. The X port should be connected to the B port (side of the logic valve), & the Z1 port should be connected to the A port (nose of the logic valve).

By using a standard D03 directional control with flow from P to A in the de-energized condition, the shuttle will use the greater pressure to hold the valve closed. Energizing the solenoid vents the pressure above the logic valve to the drain. Flow can travel freely from A to B or from B to A as long as the spring force is overcome.

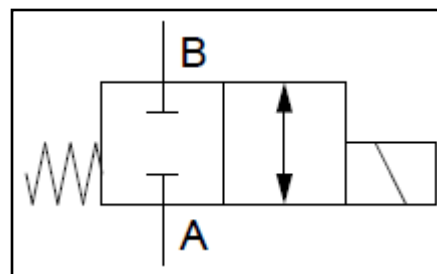
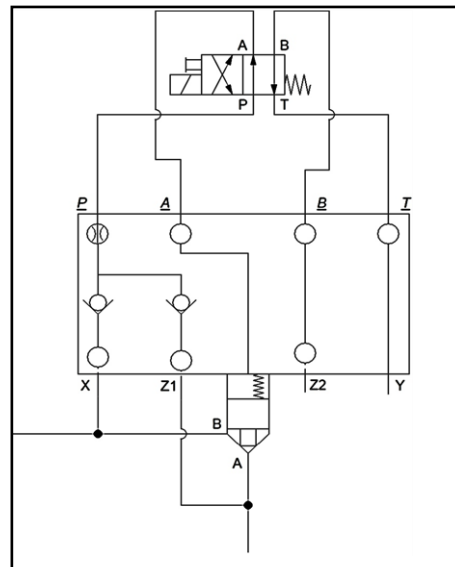

General Layout

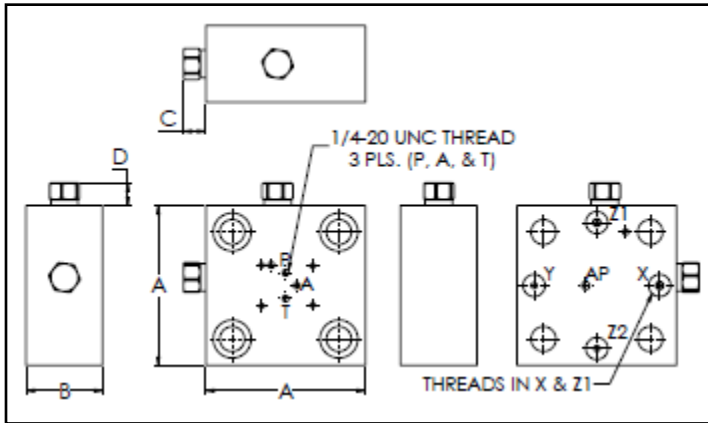

Sizes 40 mm to 50 mm
 Sizes 25 mm & 32 mm discontinued.

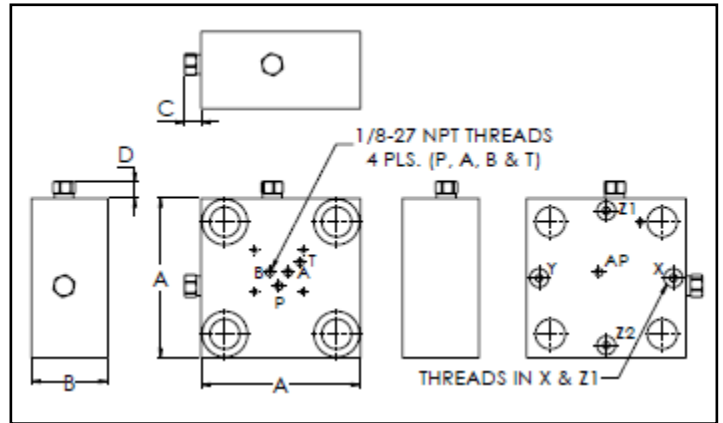

Size 63 mm

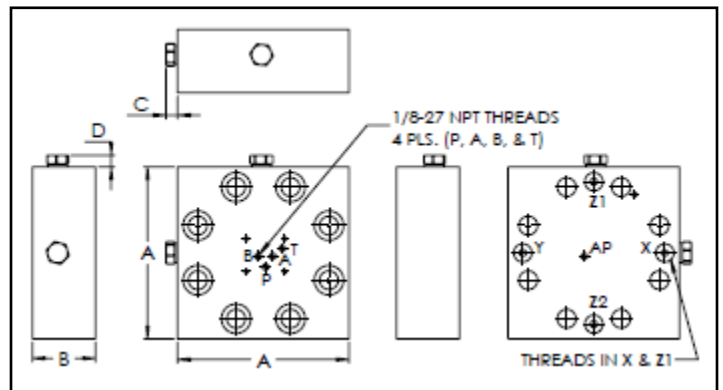

Size 80 mm

Cover Size	A	B	C	D	Interface	Threads in X & Z1	*Orifice Size in P	Bolts
40 mm	5.00"	2.40"	0.73"	0.73"	D03	1/16-27 NPT	1.5 mm	3/4-10 X 2.50" (4)
50 mm	5.55"	2.75"	0.29"	0.00"	D03	1/16-27 NPT	1.8 mm	3/4-10 X 3.00" (4)
63 mm	7.00"	3.38"	0.73"	0.73"	D05	1/8-27 NPT	2.0 mm	1-1/4-7 X 3.50" (4)
80 mm	9.50"	3.50"	0.65"	0.65"	D05	1/8-27 NPT	2.5 mm	1-8 X 4.00" (8)

*Only one orifice installed in P port of D03/D05 interface. Other orifices are optional.

Order Code

AMT-PDSH3-**-**-**

Almo
Manifold
 & **T**ool

Poppet cover with
Directional control interface
 & **S**huttle function version #3

Size: **40**, **50**, **63**, or **80** mm

Custom orifice size in
 [mm] if other than
 standard size
 Examples: 08 = 0.8 mm
 10 = 1.0 mm
 12 = 1.2 mm

BL = Include bolts at extra charge

Blank = Customer will supply bolts

DIN 24342 COVER FOR DIRECTIONAL CONTROL

SIZES 16 mm TO 80 mm

6000 PSI

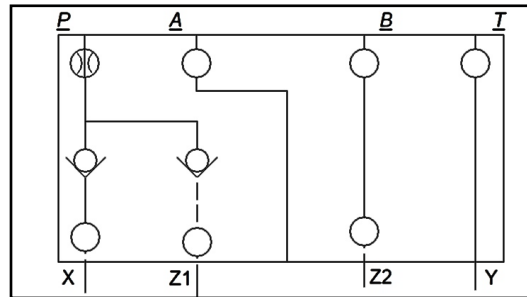

- ✓ 2 check valves senses the greater of two pressures
- ✓ Sizes 16 mm thru 63 mm: Ships with standard D03 interface (ISO 4401-03-02-0-94)
- ✓ Sizes 50 mm thru 63 mm: D05 interface optional upon request (ISO 4401-05-04-0-94)
- ✓ Size 80 mm: Ships with standard D05 interface
- ✓ Standard orifice installed in P
- ✓ Removeable orifice plug options

Applications

On/Off Valve

Will hold the valve closed in one condition and will allow the valve to open in the other condition.

Senses the greater of two pressures between the X port & the A port. The X port should be connected to the B port (side of the logic valve), & the Z1 port should be connected to the A port (nose of the logic valve).

By using a standard D03/D05 directional control with flow from P to A in the de-energized condition, the shuttle will use the greater pressure to hold the valve closed. Energizing the solenoid vents the pressure above the valve insert to the drain. Flow can travel freely from A to B or from B to A as long as the spring force is overcome.

B to Z2 allows control of an additional valve.

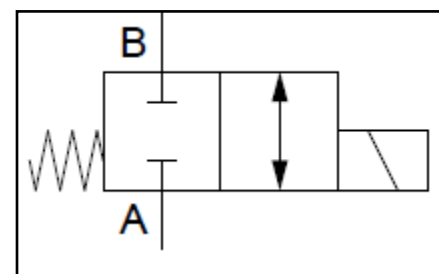
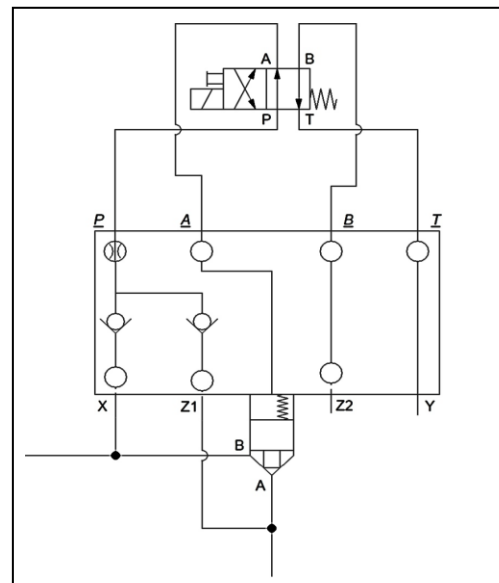

General Layout

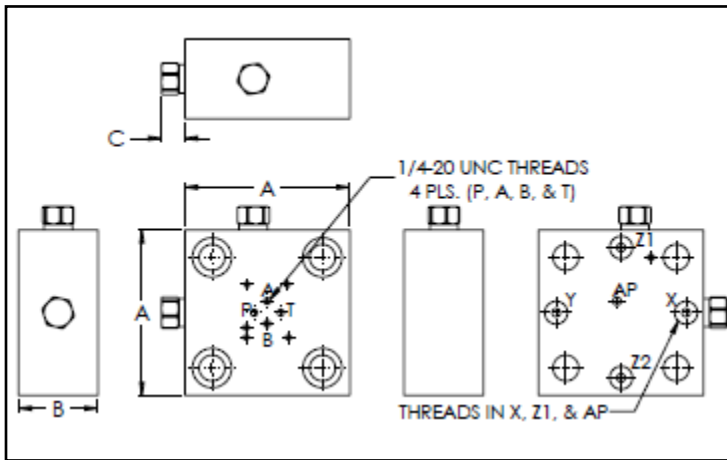

Sizes 16 mm to 63 mm with D03
50 mm only: D03 rotated 90° CW from above image

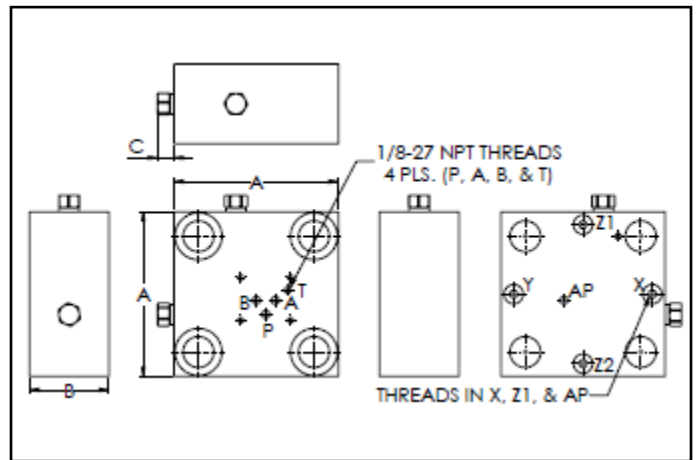

Sizes 50 mm to 63 mm with D05 (80 mm not shown)

Cover Size	A	B	C	Interface	Threads in X, Z1, & AP	*Orifice Size in P	Bolts
16 mm	3.00"	2.50"	0.45"	D03	1/4-20 UNC (X, Z1) 1/16-27 NPT (AP)	1.0 mm	5/16-18 X 2.50" (4)
25 mm	3.50"	2.00"	1.03"	D03	1/16-27 NPT	1.2 mm	1/2-13 X 2.00" (4)
32 mm	4.00"	2.00"	0.78"	D03	1/16-27 NPT	1.3 mm	5/8-11 X 2.00" (4)
40 mm	5.00"	2.40"	0.71"	D03	1/16-27 NPT	1.5 mm	3/4-10 X 3.00" (4)
50 mm	5.55"	2.75"	0.29"	D03/D05	1/16-27 NPT	1.8 mm	3/4-10 X 3.00" (4)
63 mm	7.00"	3.38"	0.71"	D03/D05	1/8-27 NPT	2.0 mm	1-1/4-7 X 3.50" (4)
80 mm	9.50"	3.50"	0.71"	D05	1/8-27 NPT	2.5 mm	1-8 X 4.00" (8)

*Only one orifice installed in P port of D03/D05 interface. Other orifices are optional.

**50 mm to 63 mm: Ships standard with D03 interface. D05 interface available upon request.

Order Code

AMT-PDSH5-**-**-**

Almo
Manifold
& **T**ool

Poppet cover with
Directional control interface
& **S**huttle function version #**5**

Size: **16**, **25**, **32**, **40**, **50**, **63**, or **80** mm

Custom orifice size in
[mm] if other than
standard size
Examples: 08 = 0.8 mm
10 = 1.0 mm
12 = 1.2 mm

BL = Include bolts at extra
charge

Blank = Customer will
supply bolts

Note: When placing a purchase order, if a D05 interface is needed for this 50 mm and/or 63 mm cover, please specify. The 50 mm and 63 mm ship standard with a D03 interface.

DIN 24342 COVER FOR PRESSURE CONTROL

SIZES 16 mm TO 80 mm

6000 PSI

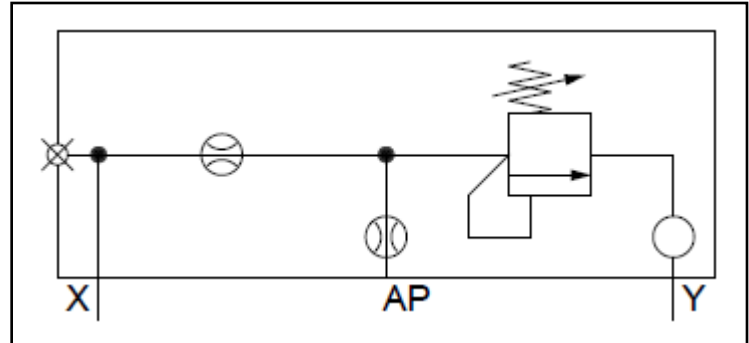

- ✓ Adjustable relief setting from 150 psi to 6000 psi
- ✓ Standard screw adjustment for relief setting. Hand knob available upon request.
- ✓ Removable NPT orifice plug options
- ✓ SAE O-ring port access to NPT orifice & gauging
- ✓ Pressure at Y is directly additive to relief setting
- ✓ Z seal recommended on logic valve when used with this cover

Applications

Relief, Back Pressure, or Sequence Valve

Provides relief function from A to B by connecting the X pilot to the A port of the logic valve. The Y port can be connected to the B port, but a separate drain line is preferred. This configuration uses a 1:1 ratio logic valve.

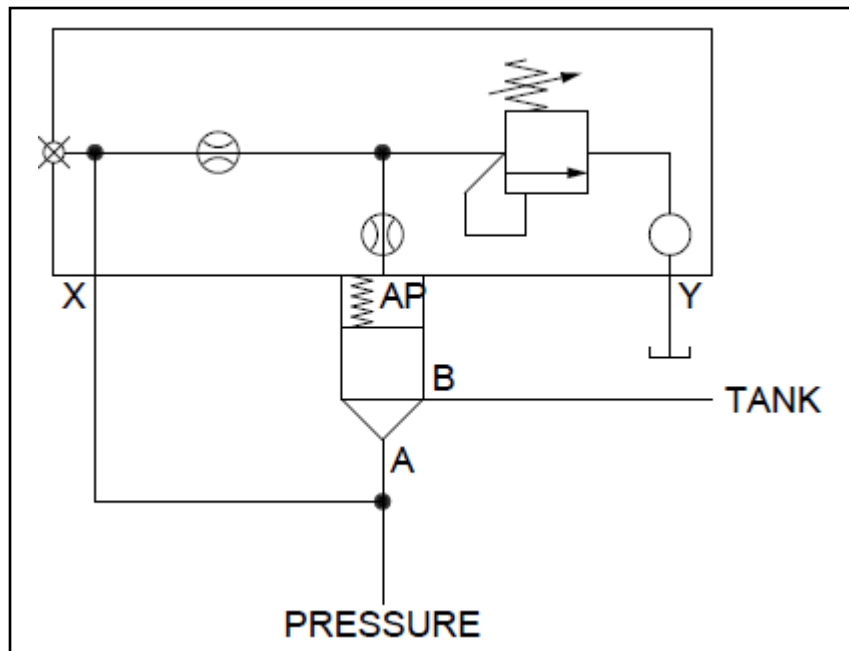
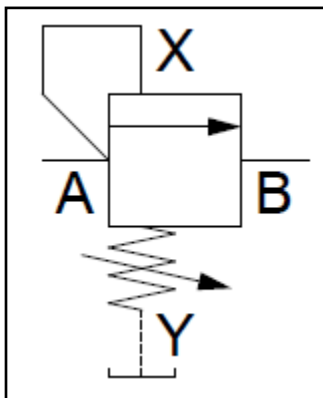

General Layout

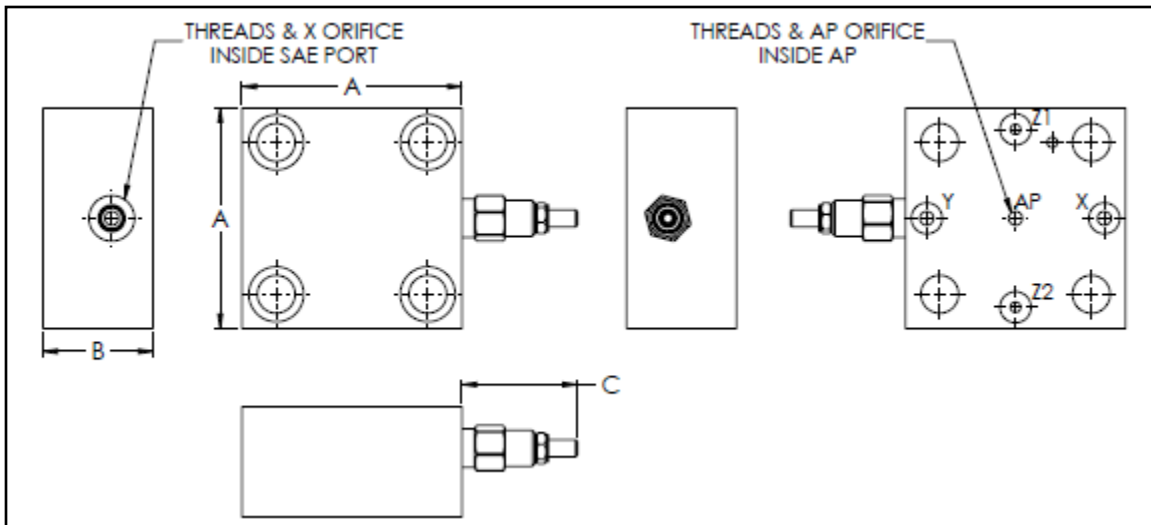

Sizes 16 mm to 63 mm (80 mm not shown)

Cover Size	A	B	C	Port Size	Threads in SAE & AP	*Orifice Size		Bolts
						X	AP	
16 mm	2.75"	1.50"	2.1"	SAE #4	1/16-27 NPT	0.7 mm	1.0 mm	5/16-18 X 1.50" (4)
25 mm	3.50"	2.00"	2.1"	SAE #4	1/16-27 NPT	0.7 mm	1.0 mm	1/2-13 X 2.00" (4)
32 mm	4.00"	2.00"	2.1"	SAE #4	1/16-27 NPT	0.7 mm	1.0 mm	5/8-11 X 2.00" (4)
40 mm	5.00"	2.40"	2.1"	SAE #4	1/16-27 NPT	0.7 mm	1.0 mm	3/4-10 X 2.50" (4)
50 mm	5.55"	2.75"	2.1"	SAE #4	1/16-27 NPT	0.7 mm	1.0 mm	3/4-10 X 3.00" (4)
63 mm	7.00"	3.38"	2.1"	SAE #6	1/8-27 NPT	0.7 mm	1.0 mm	1-1/4-7 X 3.50" (4)
80 mm	9.50"	3.50"	2.0"	SAE #6	1/8-27 NPT	0.7 mm	1.0 mm	1-8 X 4.00" (8)

*Orifices installed in X SAE port & AP port only. Other orifices are optional.

**Exception: 25 mm has X orifice installed in X port, not X SAE port. AP orifice installed in AP port.

Order Code

AMT-PRC-**-S-**-**

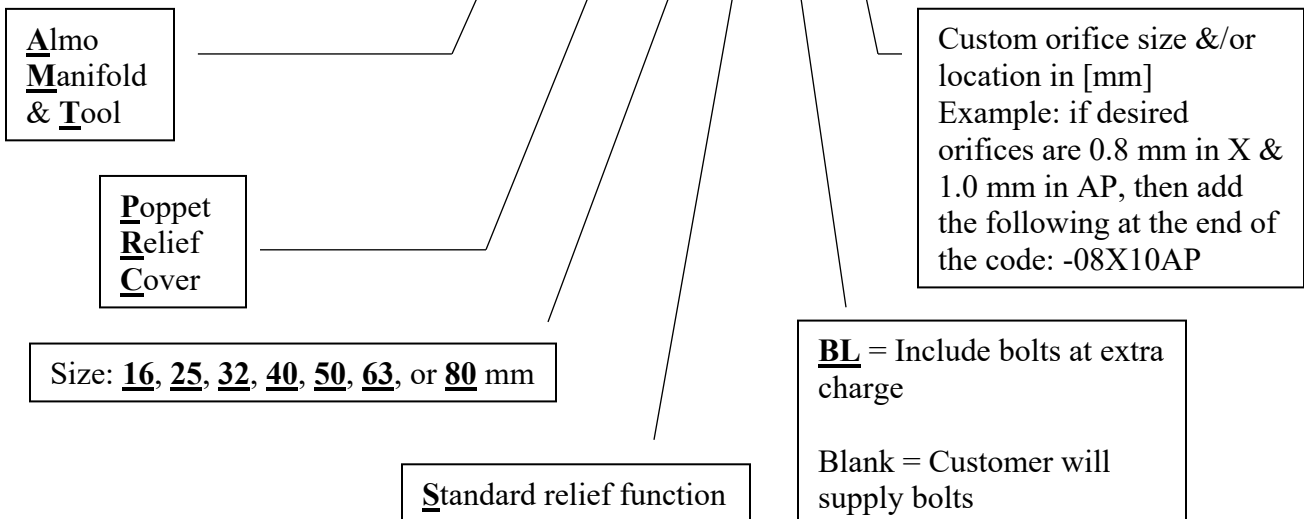

DIN 24342 COVER FOR PRESSURE CONTROL

SIZES 16 mm TO 80 mm

6000 PSI

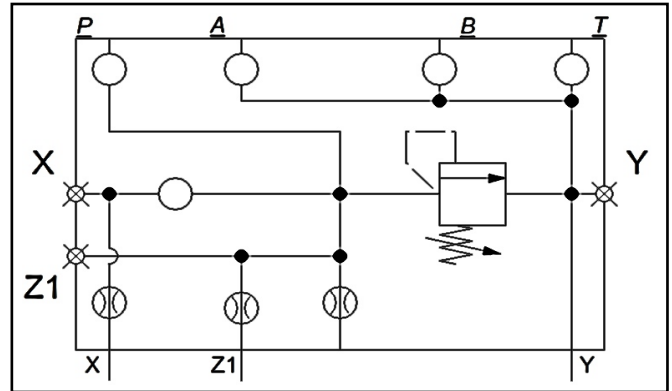

- ✓ Adjustable relief setting from 150 psi to 6000 psi
- ✓ Standard screw adjustment for relief setting. Hand knob available upon request
- ✓ Removable orifice plug options
- ✓ SAE O-ring ports for access to NPT orifices, gauging, or remote piloting
- ✓ Pressure at Y is directly additive to relief setting
- ✓ 16 mm to 40 mm: Ships standard with D03 interface for loading/venting (ISO 4401-03-02-0-94)
- ✓ 50 mm to 80 mm: Ships standard with D05 interface. 50 mm to 63 mm: D03 interface option available (ISO 4401-05-04-0-94)
- ✓ Z seal recommended on logic valve when used with this cover

Applications

Solenoid-Loading Relief Valve

Provides relief function from A to B of the logic valve by connecting the X pilot to the A port of the logic valve (shown on the left) or by connecting the Z1 port to the A port (shown on the right).

Using a standard directional control with flow from P to A or B in the de-energized condition will unload the valve. In the energized state, the system will build pressure until the relief setting is reached. The valve can be manually vented using the external X SAE port.

The Y port can be connected to the B port of the logic valve, but a separate drain connection is preferred.

This configuration uses a 1:1 ratio logic valve.

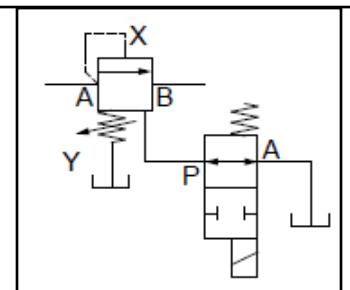
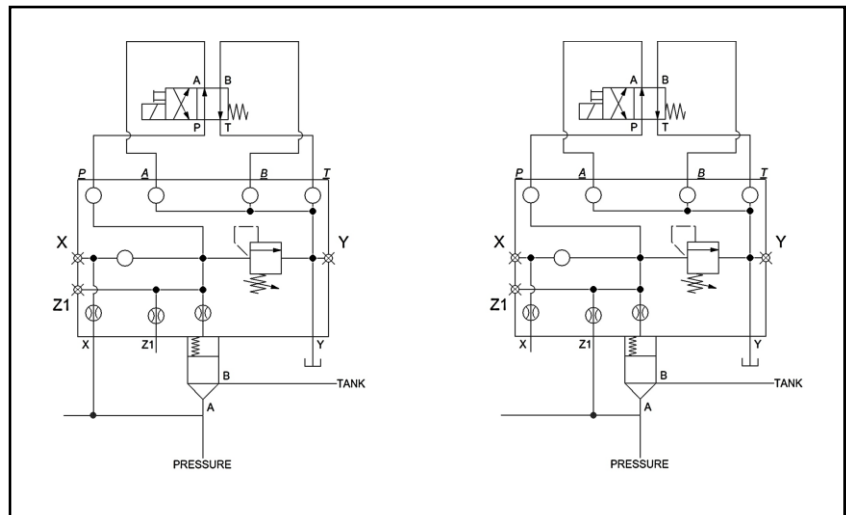

General Layout

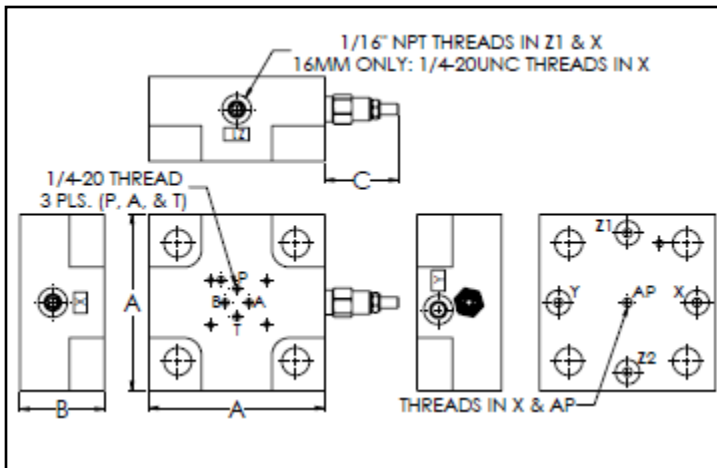

Sizes 16 mm to 40 mm

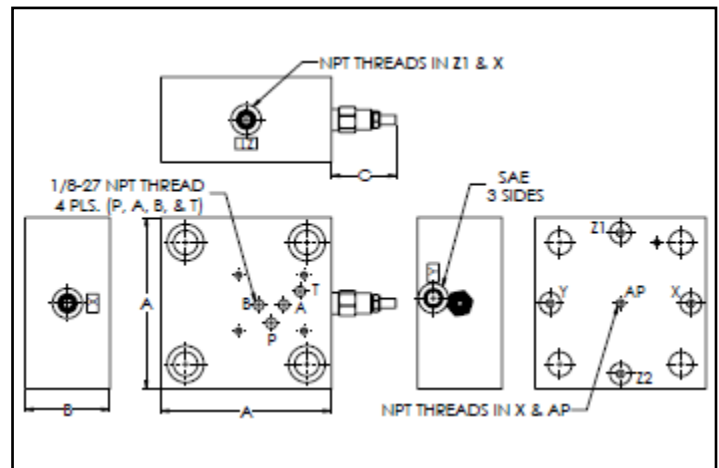

Sizes 50 mm to 63 mm (80mm not shown)

Cover Size	A	B	C	Port Size X, Z1, & Y	Interface	Threads in X & AP	*Orifice Size		Bolts
							X,Z1	AP	
16 mm	2.75"	2.50"	2.1"	1/4" NPT	D03	1/4-20 UNC (X) 1/16-27 NPT (AP)	0.7 mm	1.0 mm	5/16-18 X 2.50" (4)
25 mm	3.50"	2.25"	2.1"	SAE # 4	D03	1/16-27 NPT	0.7 mm	1.0 mm	1/2-13 X 2.25" (4)
32 mm	4.00"	2.00"	2.1"	SAE # 4	D03	1/16-27 NPT	0.7 mm	1.0 mm	5/8-11 X 2.00" (4)
40 mm	5.00"	2.40"	2.1"	SAE # 4	D03	1/16-27 NPT	0.7 mm	1.0 mm	3/4-10 X 2.50" (4)
50 mm	5.55"	2.75"	2.1"	SAE # 6	D03/D05	1/16-27 NPT	0.7 mm	1.0 mm	3/4-10 X 3.00" (4)
63 mm	7.00"	3.38"	2.1"	SAE # 6	D03/D05	1/8-27 NPT	0.7 mm	1.0 mm	1-1/4-7 X 3.50" (4)
80 mm	9.50"	3.50"	2.1"	SAE # 6	D05	1/8-27 NPT	0.7 mm	1.0 mm	1-8 X 4.00" (8)

*Orifice installed in X & AP port only. Other orifices are optional.

**50 mm to 63 mm: Ships standard with D05 interface. D03 interface available upon request.

Order Code

AMT-PRC-**-L-**-**-**

Almo
Manifold
& **T**ool

Poppet **R**elief **C**over

Size: **16**, **25**, **32**, **40**, **50**, **63**, or **80** mm

Solenoid **I**ndicator/venting
relief function

For size 50 mm – 63 mm only:
Blank = Standard D05 interface
3 = Optional D03 interface

Custom orifice size &/or
location in [mm]
Example: if desired
orifices are 0.8 mm in X &
1.0 mm in AP, then add
the following at the end of
the code: -08X10AP

Option 1: B is blocked A is open
Option 2: A is blocked B is open

BL = Include bolts at extra
charge

Blank = Customer will
supply bolts

D03 SANDWICH RELIEF ACCESSORY

NFPA D03, CETOP3

6000 PSI



- ✓ Relief accessory for AMT-PRC-**-L relief covers
- ✓ Adjustable relief setting from 150 psi to 5000 psi
- ✓ Standard screw adjustment for relief setting
- ✓ Pressure at T is directly additive to relief setting

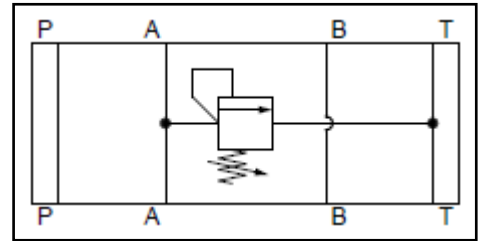

Above: AT option
Below: BT option

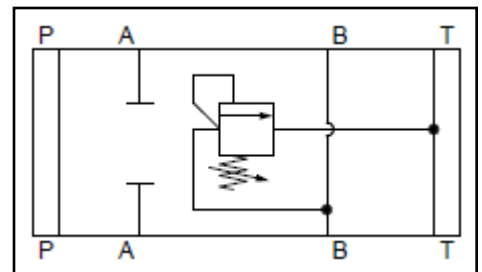

Applications

High/Low Pressure Relief Valve

This D03 relief sandwich accessory can be combined with an AMT-PRC-**-L to create a high/low relief valve with two independent relief settings.

Using a standard directional control with flow from P to A in the de-energized condition will select the relief setting of the cover. Energizing the pilot valve will switch the relief setting to the accessory.

Note: The relief setting of the accessory must be lower than the setting of the cover.

The Y pilot can be connected to the B port of the logic valve, but a separate drain connection is preferred.

This configuration uses a 1:1 ratio logic valve.

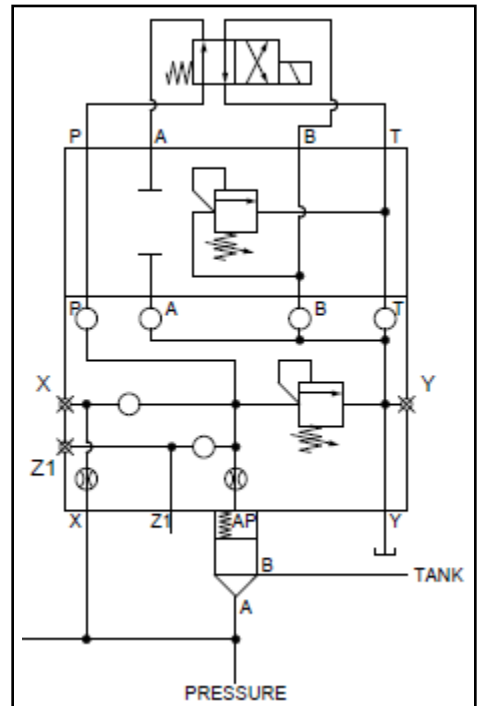
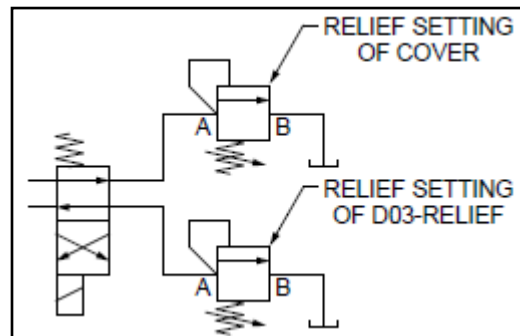

General Layout

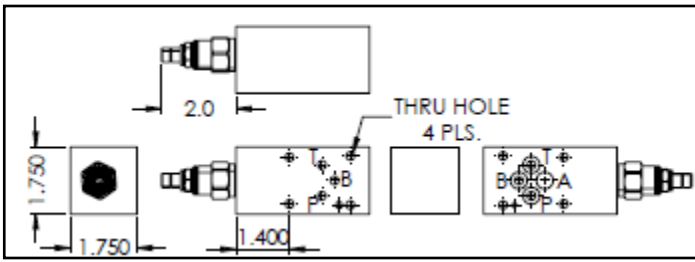

AMT-D03-Relief-

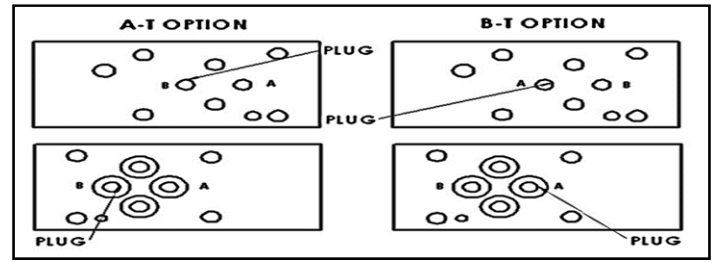

Order Code

To order the D03 relief accessory individually, use the following code:

AMT-D03-Relief-**

Almo
Manifold
& Tool

D03 interface

Sandwich accessory
with relief function

AT = Relief function from
A to T

BT = Relief function from
B to T

To order the D03 relief accessory and the DIN cover together, use the code below:

AMT-PRC-**-HL*-*-**

Almo
Manifold
& Tool

Poppet
Relief
Cover

Size: 16, 25, 32, or 40 mm

High/Low relief cover. Choose A or B style:
A = A to T D03 relief accessory
B = B to T D03 relief accessory

Custom orifice size &/or
location in [mm]
Example: if desired
orifices are 0.8 mm in X &
1.0 mm in AP, then add
the following at the end of
the code: -08X10AP

BL = Include bolts at extra
charge

Blank = Customer will
supply bolts

Note: The D03 accessory & DIN cover can be ordered separately. This code is for convenience only.

DIN 24342 COVER FOR FLOW CONTROL

SIZES 16 mm TO 80 mm

6000 PSI

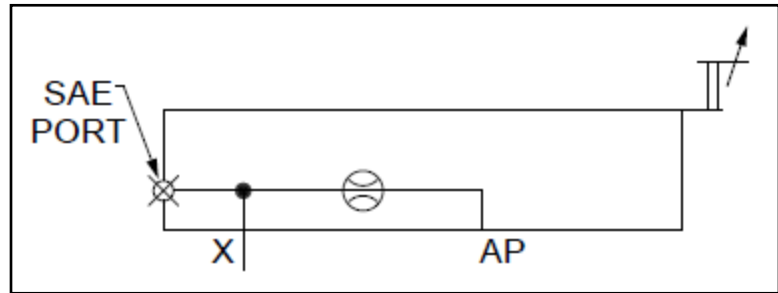

- ✓ Adjustable stroke-limiting cover for decreasing the traveling distance of the logic valve
- ✓ Set screws for locking
- ✓ SAE O-ring port for access to NPT orifice & gauging
- ✓ Removable orifice plug options

Applications

Check/Flow Control Valve

Provides metered flow from A to B (see bottom left image) & the check function from B to A (see bottom right image) by connecting the X pilot to the B port of the logic valve.



Note: To eliminate the check valve function & only use the metering capabilities, connect the X pilot to a drain line instead of connecting the X pilot to the B port.

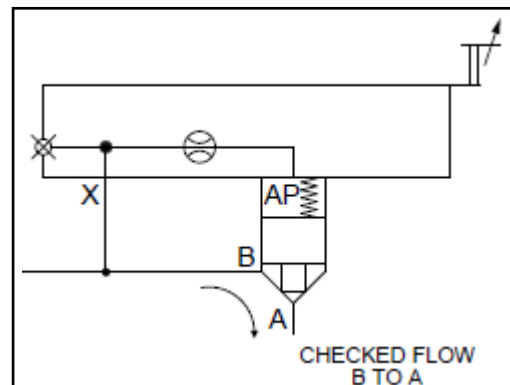
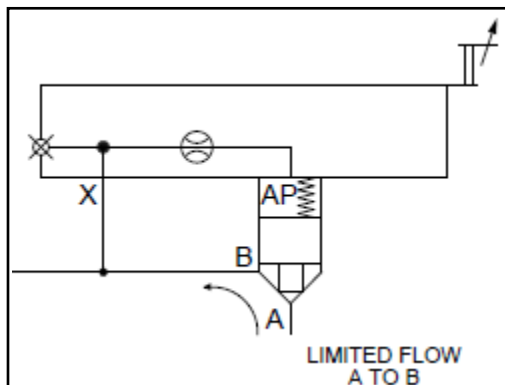

General Layout

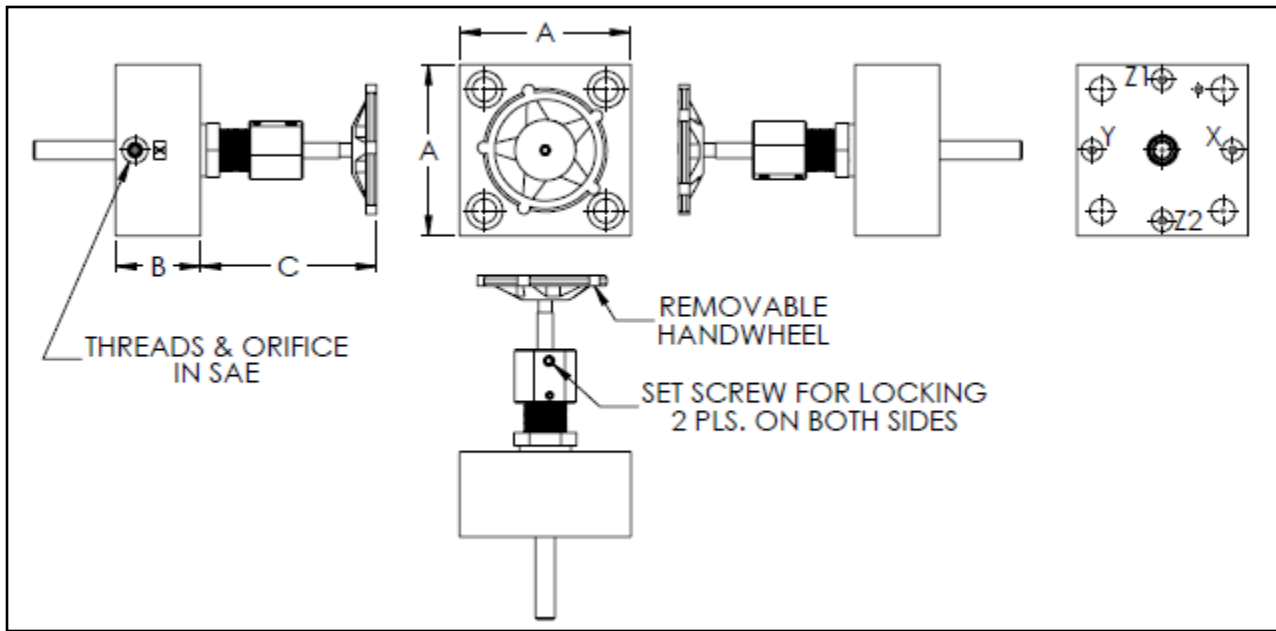

Sizes 16 mm to 63 mm (80 mm not shown)

Cover Size	A	B	C	Port Size	Orifice in X SAE		Bolts
					Threads	Size	
16 mm	2.75"	1.50"	2.80"	SAE #4	1/16-27 NPT	1.0 mm	5/16-18 X 1.50" (4)
25 mm	3.50"	2.00"	4.00"	SAE #4	1/16-27 NPT	1.2 mm	1/2-13 X 2.00" (4)
32 mm	4.00"	2.00"	4.00"	SAE #4	1/16-27 NPT	1.3 mm	5/8-11 X 2.00" (4)
40 mm	5.00"	2.40"	5.50"	SAE #4	1/16-27 NPT	1.5 mm	3/4-10 X 2.50" (4)
50 mm	5.55"	2.75"	5.40"	SAE #4	1/16-27 NPT	1.8 mm	3/4-10 X 3.00" (4)
63 mm	7.00"	3.50"	7.00"	SAE #6	1/8-27 NPT	2.0 mm	1-1/4-7 X 3.50" (4)
80 mm	9.50"	3.50"	7.10"	SAE #6	1/8-27 NPT	2.5 mm	1-8 X 4.00" (8)

Order Code

AMT-PSTK-**-**-**

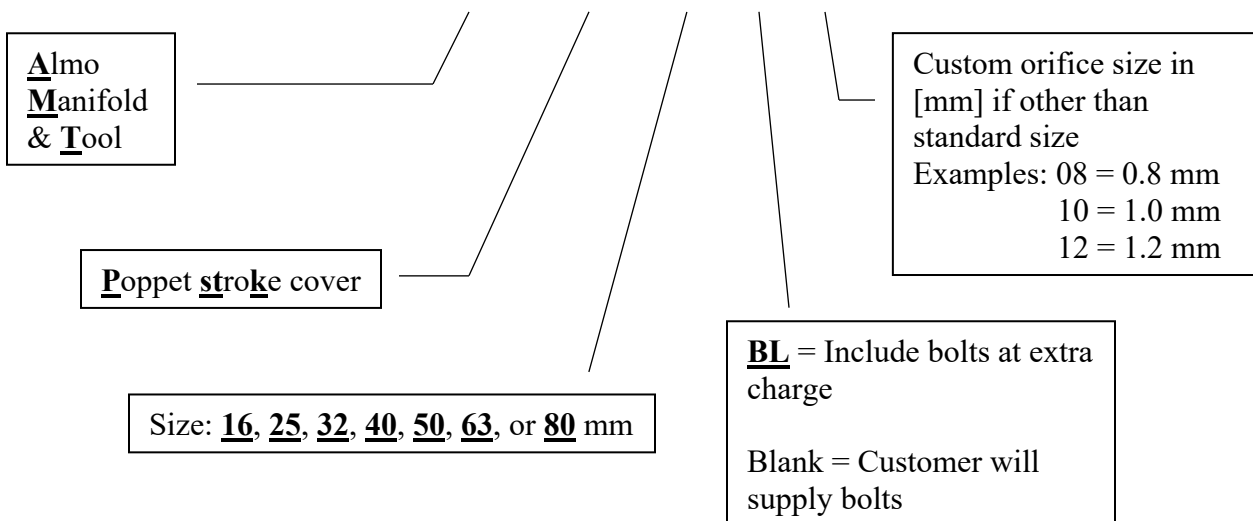

DIN 24342 COVER FOR FLOW CONTROL

SIZES 16 mm TO 80 mm

6000 PSI

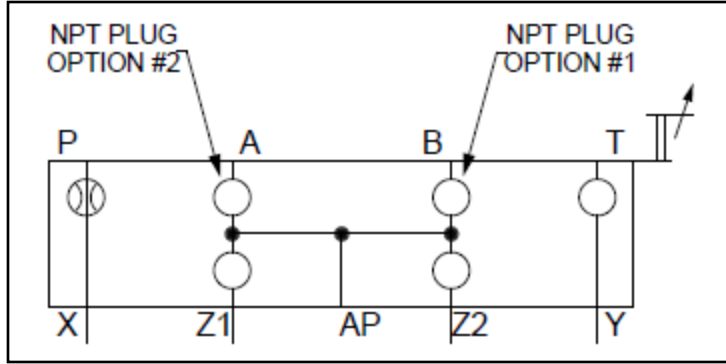

- ✓ Adjustable stroke-limiting cover for decreasing the traveling distance of the logic valve
- ✓ Set screws for locking
- ✓ A solenoid or B solenoid options
- ✓ Ships standard with an orifice installed in the P port & a plug in the B port of the D03 (D05 for 80 mm)
- ✓ Removable orifices plug options

Applications

Directional/Flow Control Valve

By connecting the X port to the B port (side of the logic valve) & connecting the Y port to drain, you can create a directional valve with flow control. Plug option #1 will allow the valve to dump in the energized state. Plug option #2 will allow the valve to dump in the de-energized state.

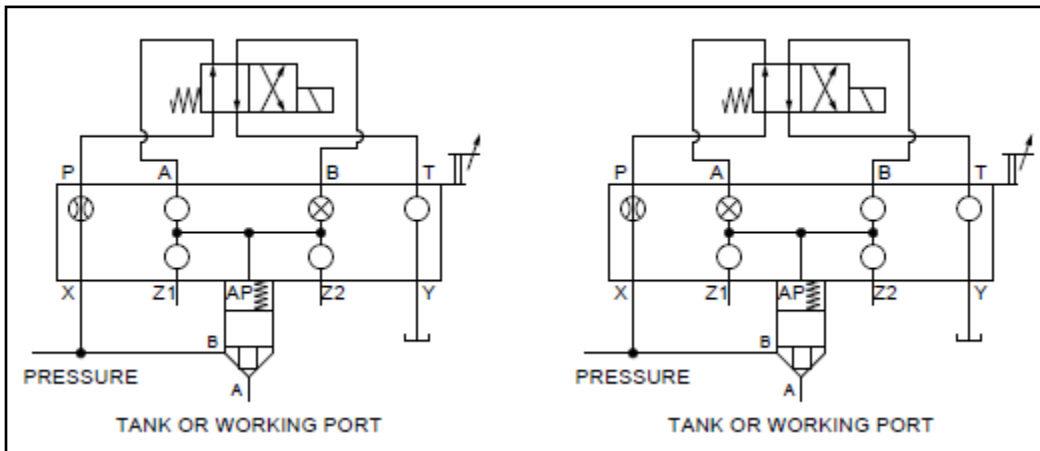
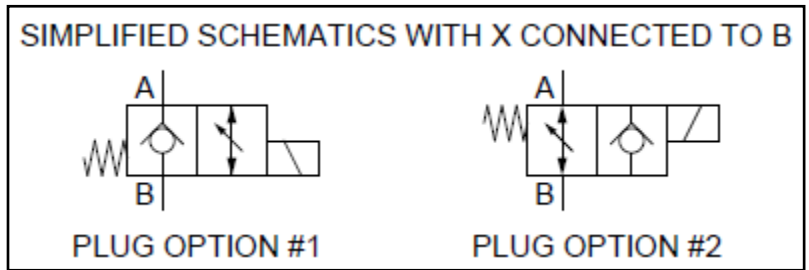

Left: Plug option #1
(standard plug option)

Right: Plug option #2

General Layout

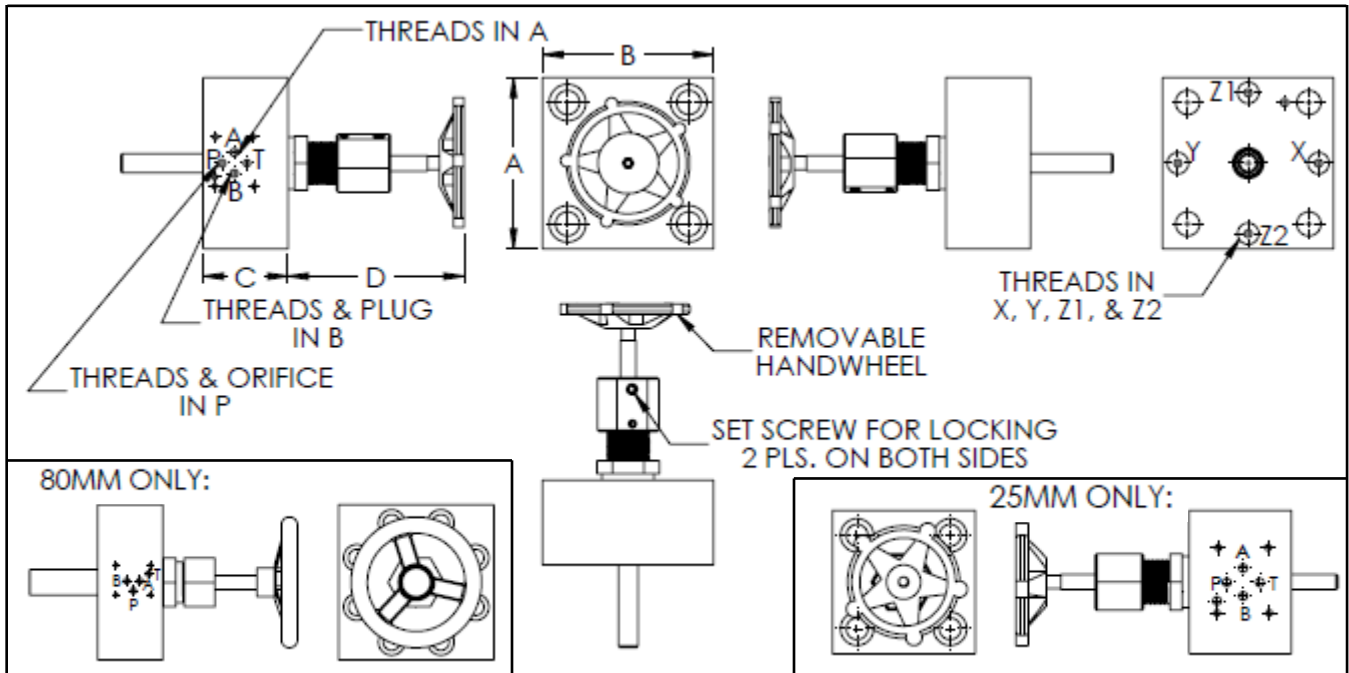

Sizes 16 mm to 63 mm (80 mm with D05 interface shown in bottom left corner)

Cover Size	A	B	C	D	Threads in X, Z1, Z2, & Y	*Orifice in P		Bolts
						Threads	Size	
16 mm	2.75"	3.00"	3.00"	2.80"	1/4-20 UNC	1/4-20 UNC	1.0 mm	5/16-18 X 3.00" (4)
25 mm	3.50"	3.50"	2.50"	4.00"	1/16-27 NPT	1/4-20 UNC	1.2 mm	1/2-13 X 2.75" (4)
32 mm	4.00"	4.00"	3.25"	4.00"	1/16-27 NPT	1/4-20 UNC	1.3 mm	5/8-11 X 3.25 (4)
40 mm	5.00"	5.00"	2.40"	5.50"	1/16-27 NPT	1/4-20 UNC	1.5 mm	3/4-10 X 2.50" (4)
50 mm	5.55"	5.55"	2.75"	5.40"	1/16-27 NPT	1/4-20 UNC	1.8 mm	3/4-10 X 3.00" (4)
63 mm	7.00"	7.00"	3.50"	7.00"	1/16-27 NPT	1/4-20 UNC	2.0 mm	1-1/4-7 X 3.50" (4)
80 mm	9.50"	9.50"	4.00"	7.10"	1/8-27 NPT	1/8-27 NPT	2.5 mm	1-8 X 5.00" (8)

*Only one orifice installed in P port of D03/D05 interface. Other orifices are optional.

Order Code

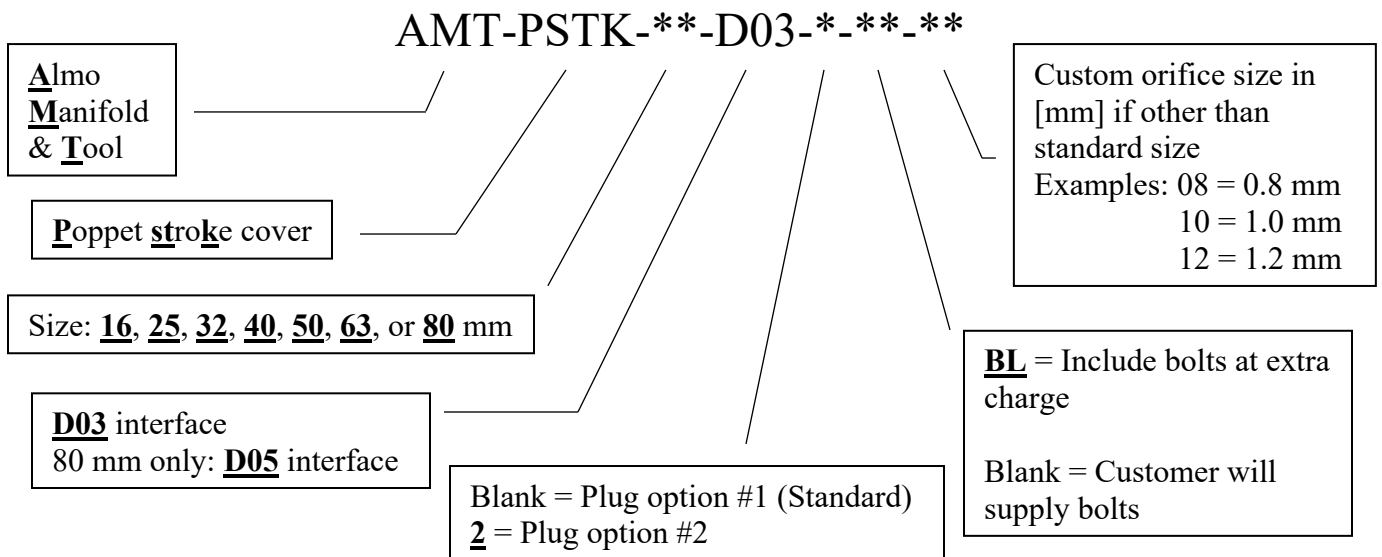

DIN 24342 COVER FOR FLOW CONTROL

SIZES 16 mm TO 63 mm

6000 PSI

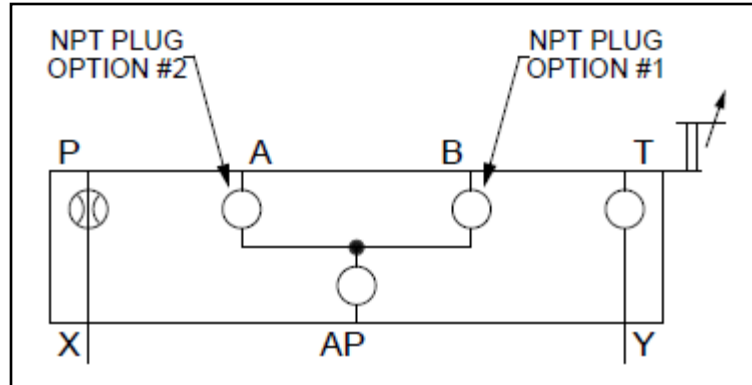

- ✓ Adjustable stroke-limiting cover for decreasing the traveling distance of the logic valve
- ✓ Set screws for locking
- ✓ A solenoid or B solenoid options
- ✓ Ships standard with an orifice installed in the P port & a plug in the B port of the D03 interface
- ✓ Removable orifices plug options

Applications

Directional/Flow Control Valve

By connecting the X port to the B port (side of the logic valve) & connecting the Y port to drain, you can create a directional valve with flow control. Plug option #1 will allow the valve to dump in the energized state. Plug option #2 will allow the valve to dump in the de-energized state.

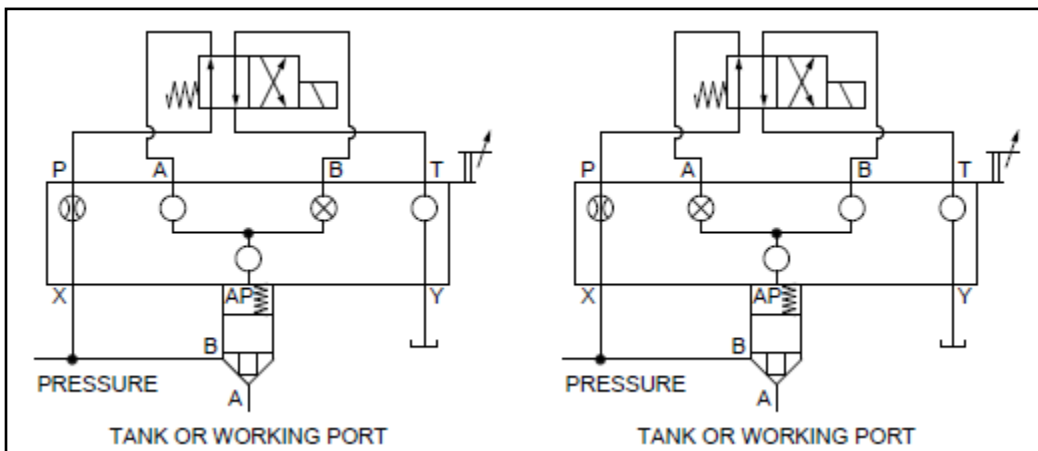
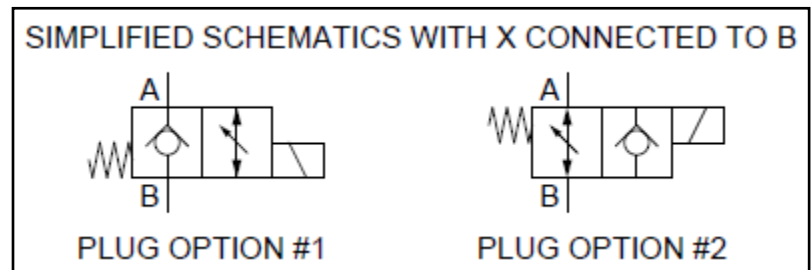

Left: Plug option #1
(standard plug option)

Right: Plug option #2

General Layout

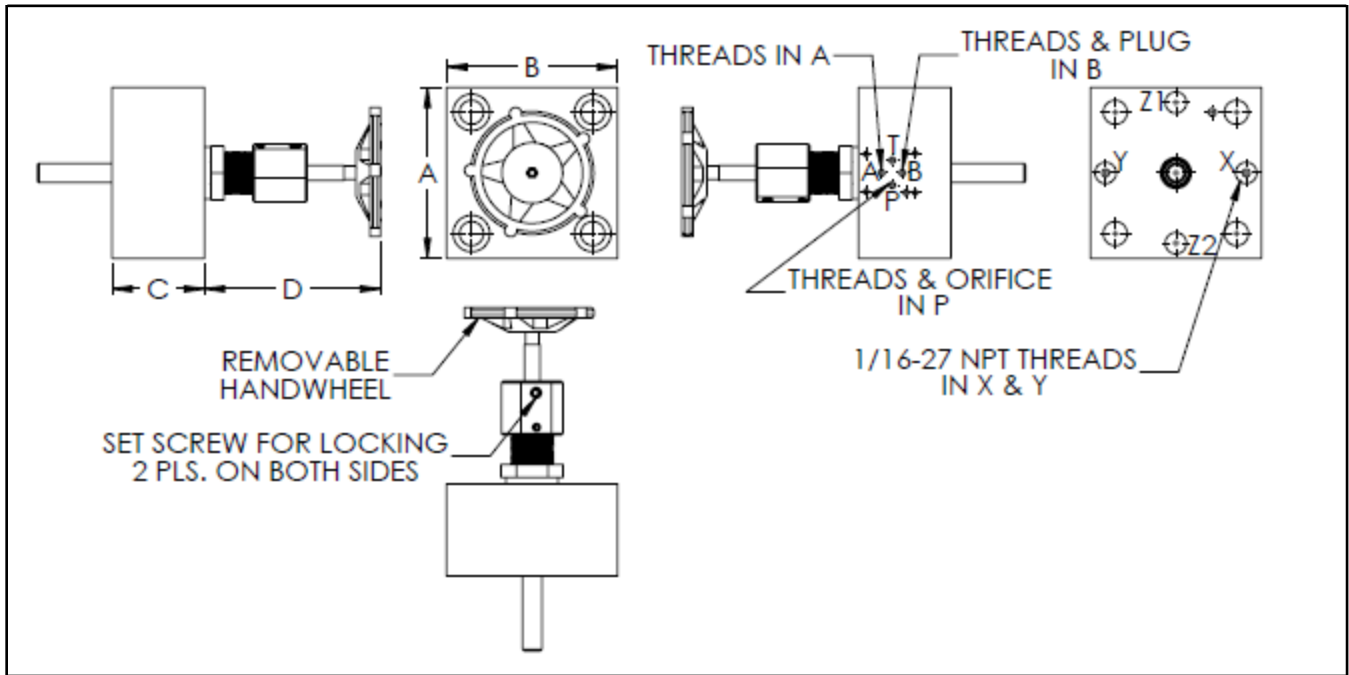

Sizes 16 mm to 63 mm

Cover Size	A	B	C	D	Threads in X, Z1, Z2, & Y	*Orifice in P		Bolts
						Threads	Size	
16 mm	2.75"	3.00"	3.00"	2.80"	1/4-20 UNC	1/4-20 UNC	1.0 mm	5/16-18 X 3.00" (4)
25 mm	3.50"	3.50"	3.00"	4.00"	1/16-27 NPT	1/4-20 UNC	1.2 mm	1/2-13 X 3.00" (4)
32 mm	4.00"	4.00"	3.00"	4.00"	1/16-27 NPT	1/4-20 UNC	1.3 mm	5/8-11 X 3.25" (4)
40 mm	5.00"	5.00"	3.00"	5.50"	1/16-27 NPT	1/4-20 UNC	1.5 mm	3/4-10 X 2.75" (4)
50 mm	5.55"	5.55"	3.00"	5.40"	1/16-27 NPT	1/4-20 UNC	1.8 mm	3/4-10 X 3.00" (4)
63 mm	7.00"	7.00"	3.50"	7.00"	1/16-27 NPT	1/4-20 UNC	2.0 mm	1-1/4-7 X 3.50" (4)

*Only one orifice installed in P port of D03 interface. Other orifices are optional.

Order Code

AMT-PSTKY-**-D03-*_*_*-**

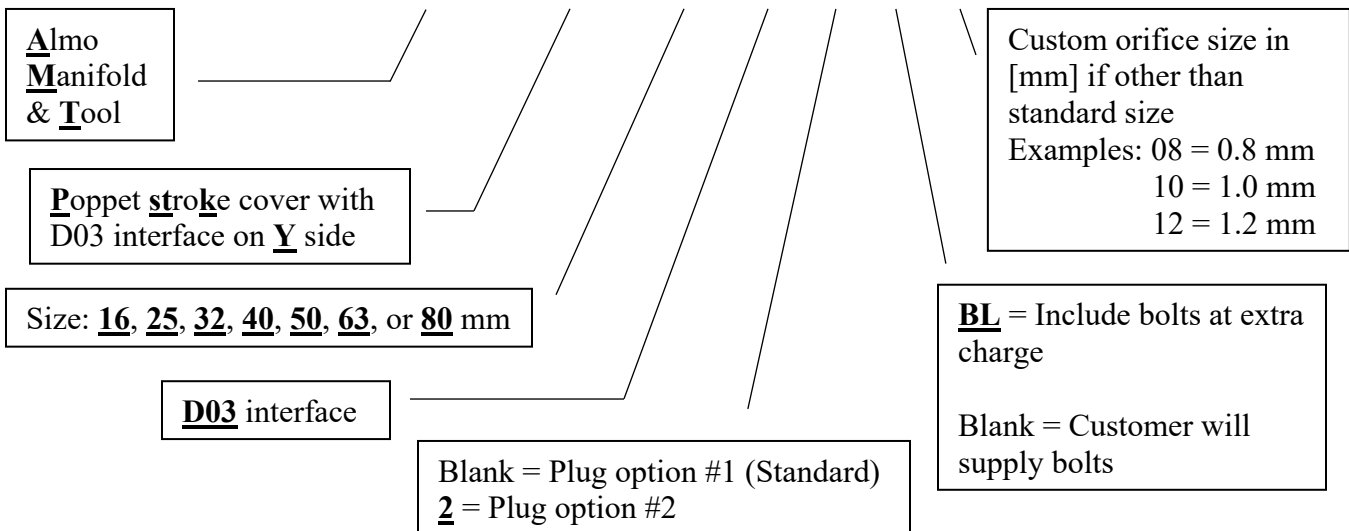

DIN 24342 COVER FOR FLOW CONTROL

SIZES 25 mm TO 63 mm

6000 PSI

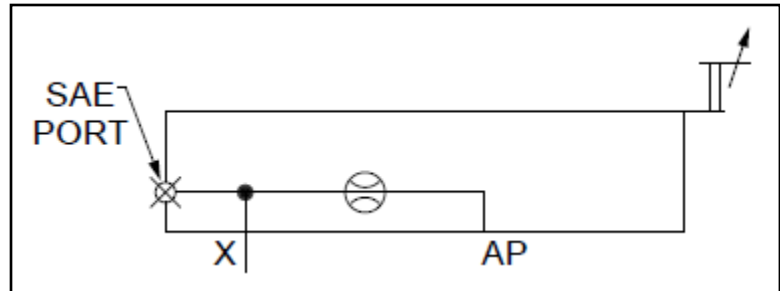

- ✓ Adjustable stroke-limiting cover for decreasing the traveling distance of the logic valve
- ✓ Stroke adjustment under SAE plug for tamper resistance & protection from elements
- ✓ Jam nut for locking
- ✓ SAE O-ring port for gauging & access to orifice
- ✓ Removable orifice plug options

Applications

Check/Flow Control Valve

Provides metered flow from A to B (see bottom left image) & the check function (see bottom right image) from B to A by connecting the X pilot to the B port of the logic valve.

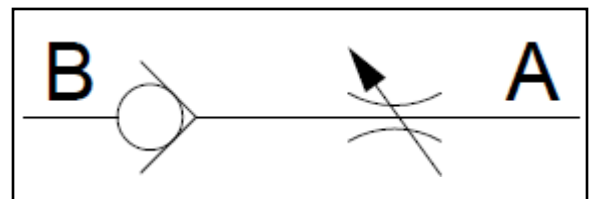

Note: To eliminate the check valve function & only use the metering capabilities, connect the X pilot to a drain line instead of connecting the X pilot to the B port.

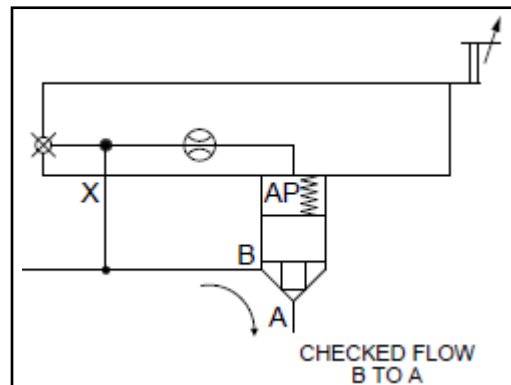
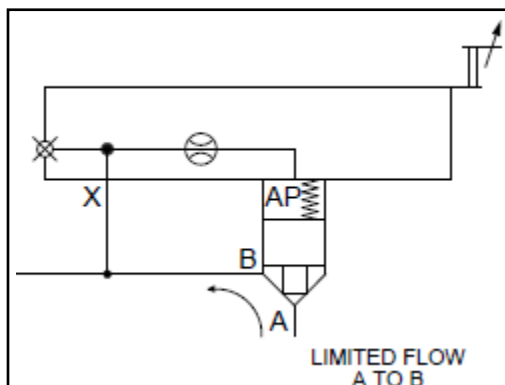

General Layout

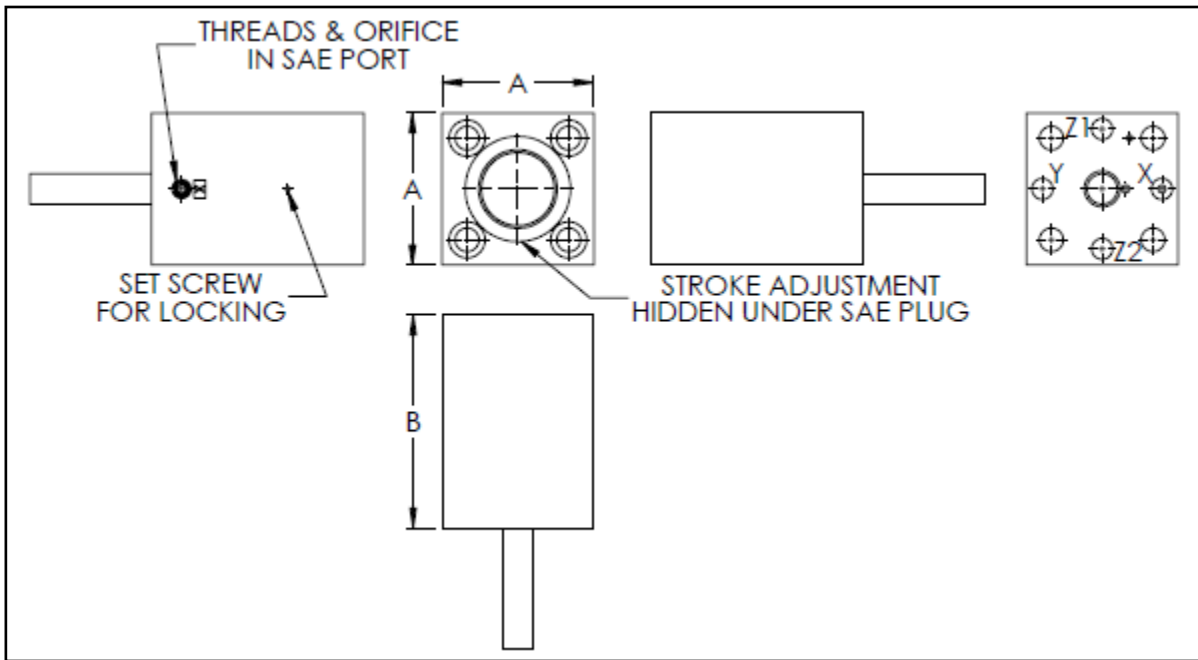

Sizes 25 mm to 63 mm

Cover Size	A	B	Port Size	*Orifice in X SAE Port		Bolts
				Threads	Size	
25 mm	3.50"	5.00"	SAE #4	1/16-27 NPT	1.2 mm	1/2-13 X 5.00" (4)
32 mm	4.00"	5.00"	SAE #4	1/16-27 NPT	1.3 mm	5/8-11 X 5.00" (4)
40 mm	5.00"	7.00"	SAE #4	1/16-27 NPT	1.5 mm	3/4-10 X 6.00" (4)
50 mm	5.50"	7.00"	SAE #4	1/16-27 NPT	1.8 mm	3/4-10 X 6.00" (4)
63 mm	7.00"	7.00"	SAE #6	1/8-27 NPT	2.0 mm	1-1/4-7 X 7.00" (4)

*Only one orifice installed in X SAE port. Other orifices are optional.

Order Code

AMT-PSLSH-**-**-**

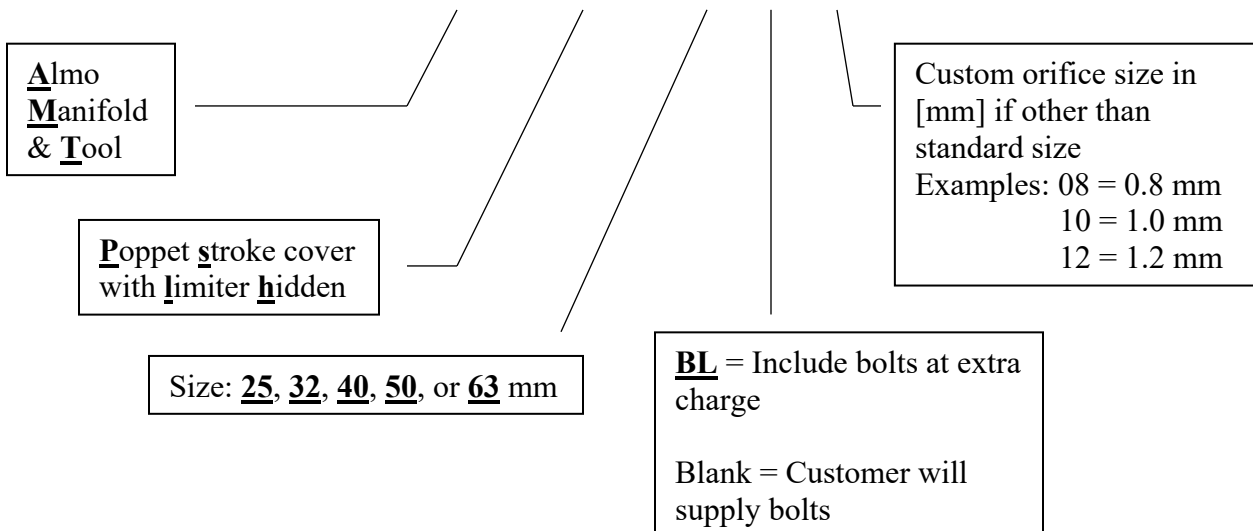

NOTES:

ACTIVE POPPETS

DIN 24342 ACTIVE POPPET

SIZES 16 mm TO 50 mm

6000 PSI

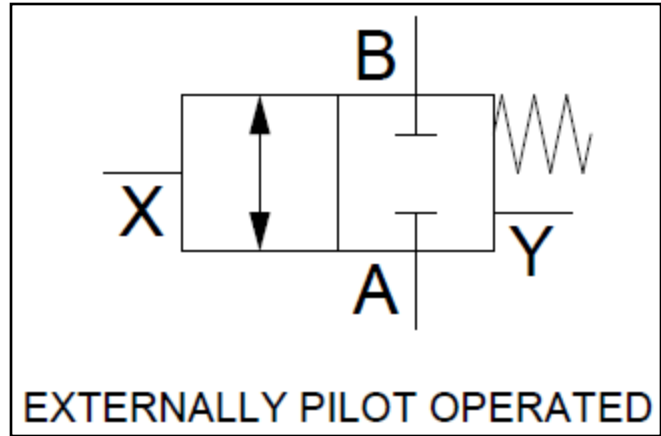

- ✓ Standard ISO 7368 & DIN 24342 cavity & porting
- ✓ Control areas provide fast response time
- ✓ Can close poppet under high load pressure

Applications

Active Poppet

The active poppet is pilot operated to cut off the main hydraulic supply to the circuit. In some circumstances, it can be used as a prefill valve.

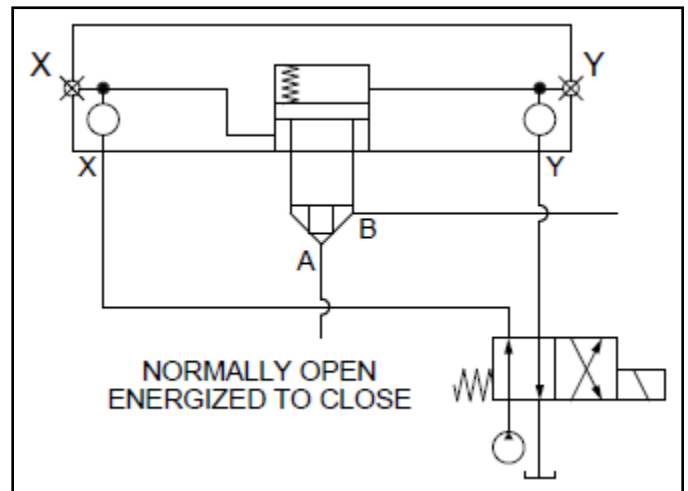
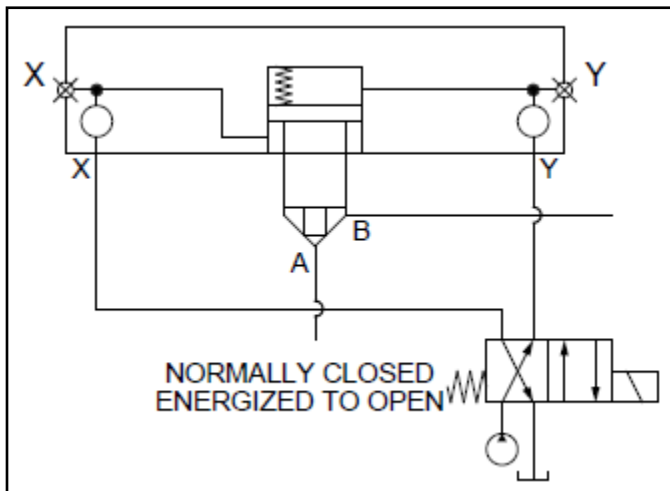

General Layout

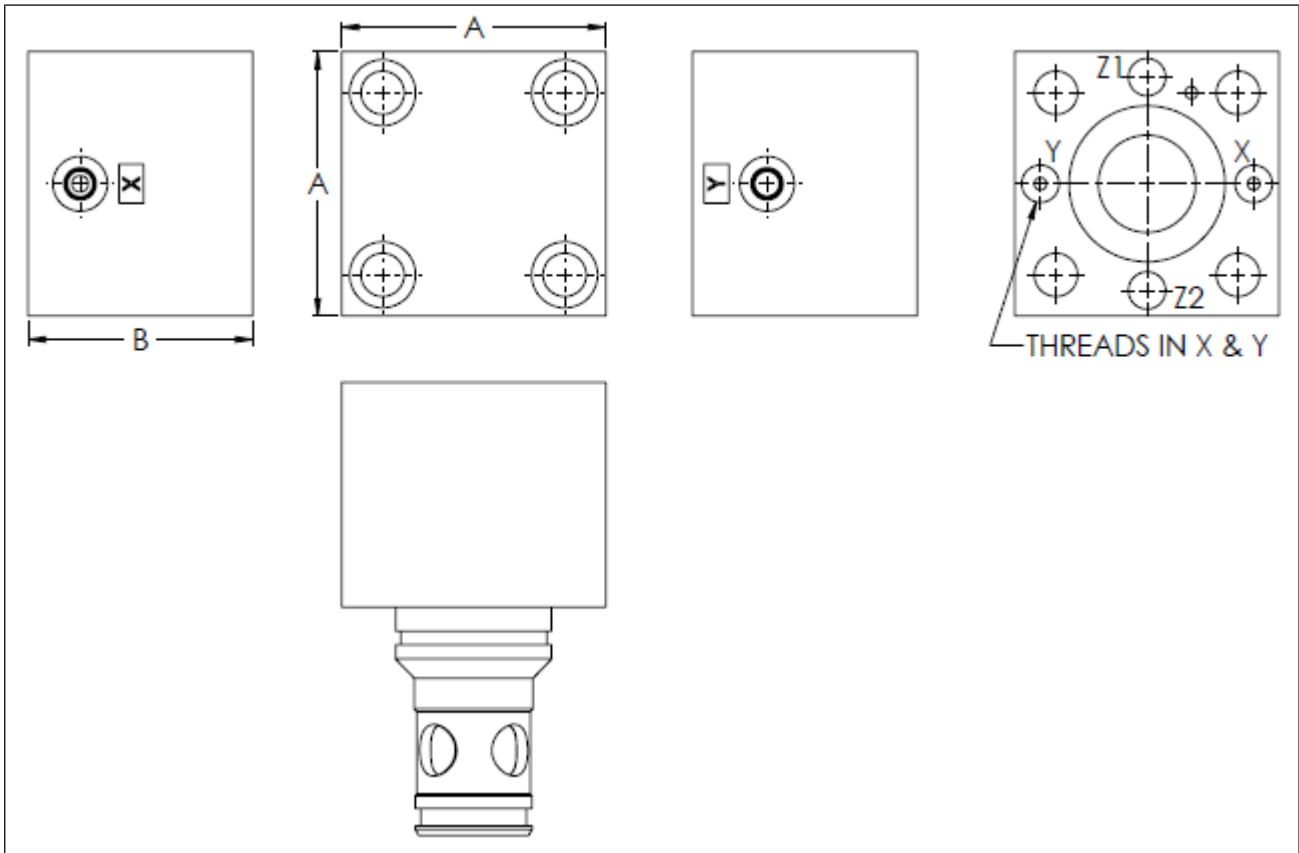

Sizes 16 mm to 50 mm

Cover Size	Flow	A	B	External X & Y Port Sizes	Threads in Internal X & Y	Bolts
16 mm	80 GPM	2.75"	2.50"	1/16-27 NPT	1/4-20 UNC	5/16-18 X 2.50" (4)
25 mm	100 GPM	3.50"	3.30"	1/16-27 NPT	1/4-20 UNC	1/2-13 X 3.50" (4)
32 mm	200 GPM	4.00"	3.40"	SAE #4	1/16-27 NPT	5/8-11 X 3.50 (4)
40 mm	350 GPM	5.00"	4.61"	SAE #4	1/16-27 NPT	3/4-10 X 4.50" (4)
50 mm	450 GPM	5.50"	6.00"	SAE #4	1/16-27 NPT	3/4-10 X 5.00" (4)

Order Code

AMT-ACT-**-**

Almo
Manifold
& **T**ool

Active poppet & cover

BL = Include bolts at extra charge

Blank = Customer will supply bolts

Size: 16, 25, 32, 40, or 50 mm

DIN 24342 ACTIVE DIRECTIONAL CONTROL POPPET

SIZES 16 mm TO 50 mm

6000 PSI

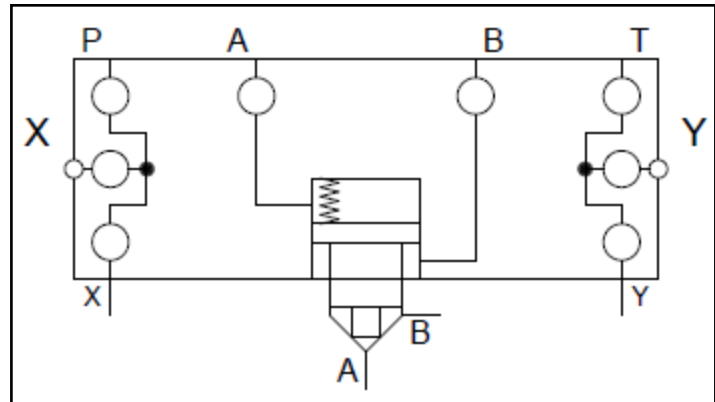

- ✓ Standard ISO & DIN 23432 cavity & porting
- ✓ Control areas provide fast response time
- ✓ Can close poppet under high load pressure
- ✓ Allows pilot-to-open/pilot-to-close
- ✓ Proportional option without feedback

Applications

Active Directional Control Poppet

The active directional control poppet is pilot-operated to cut off the main hydraulic supply to the circuit. The directional control valve regulates when the poppet is open or closed. The directional control D03 valve can receive the pilot pressure internally or externally. The D03 valve can also be internally or externally drained.

The active directional control poppet can be used in a variety of applications, including: prefill valve, pilot-operated check, proportional flow control valve, etc.

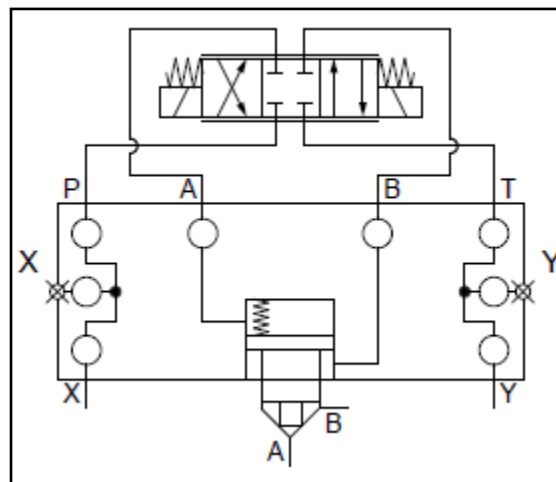
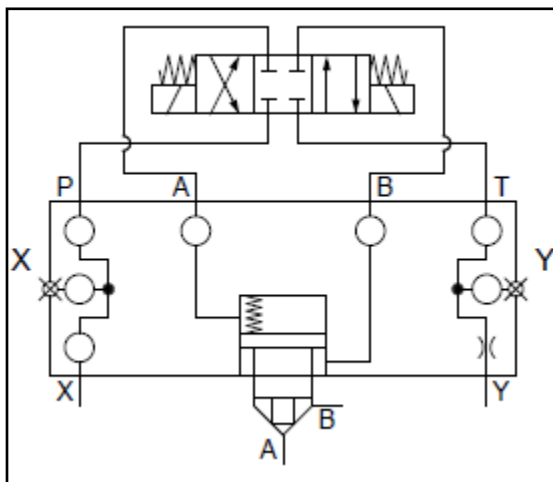

Left: Active directional control poppet & cover with a D03 valve

Right: Active directional control poppet & cover with a proportional D03 valve

General Layout

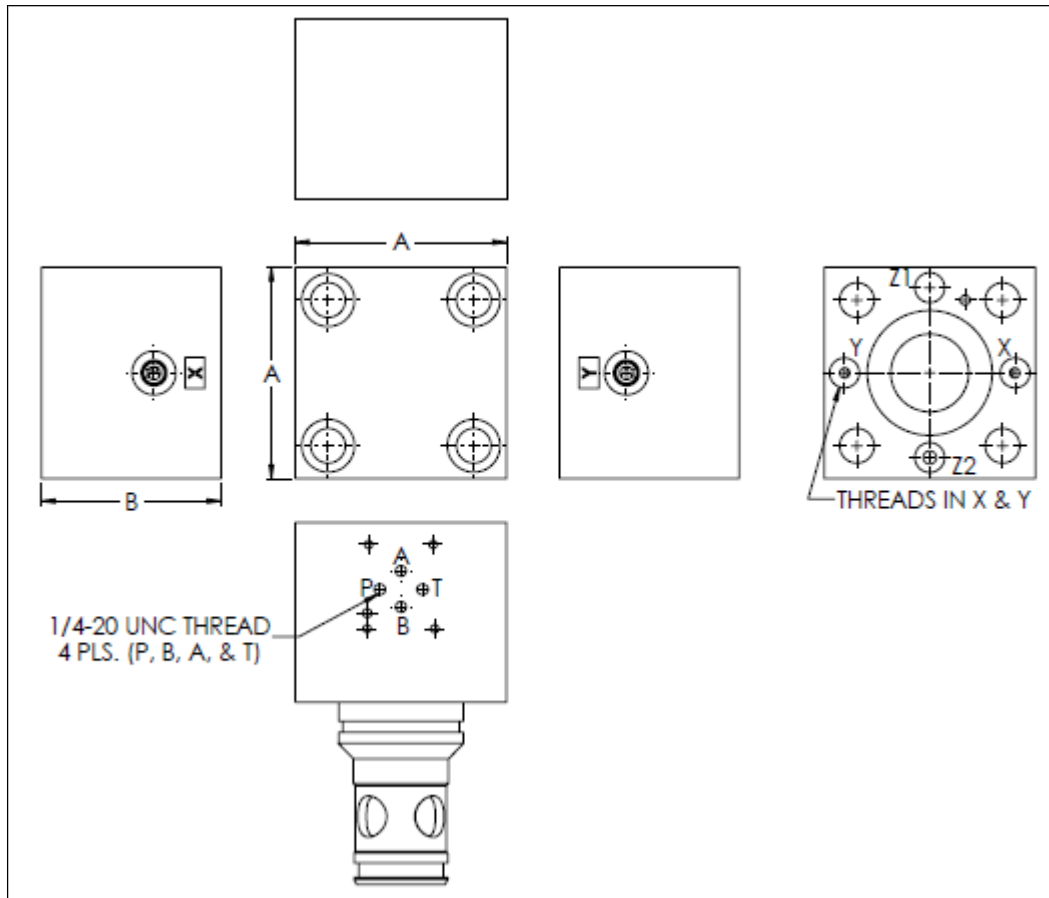

Sizes 16 mm to 50 mm

Cover Size	Flow	A	B	External X & Y Port Sizes	Threads in Internal X & Y	Bolts
16 mm	80 GPM	2.75"	3.13"	SAE# 4	1/4-20 UNC	5/16-18 X 3.50" (4)
25 mm	100 GPM	3.50"	3.30"	SAE# 4	1/4-20 UNC	1/2-13 X 3.50" (4)
32 mm	200 GPM	4.00"	3.40"	SAE# 4	1/16-27 NPT	5/8-11 X 3.50 (4)
40 mm	350 GPM	5.00"	4.61"	SAE# 4	1/16-27 NPT	3/4-10 X 4.50" (4)
50 mm	450 GPM	5.50"	6.00"	SAE# 4	1/16-27 NPT	3/4-10 X 5.00" (4)

Order Code

AMT-ACTD03-**-**

Almo
Manifold
& **T**ool

Active poppet & cover
with **D03** interface

Size: 16, 25, 32, 40, or 50 mm

BL = Include bolts at extra charge

Blank = Customer will supply bolts

DIN 24342 STROKE LIMITING ACTIVE DIRECTIONAL CONTROL POPPET

SIZES 16 mm TO 50 mm

6000 PSI

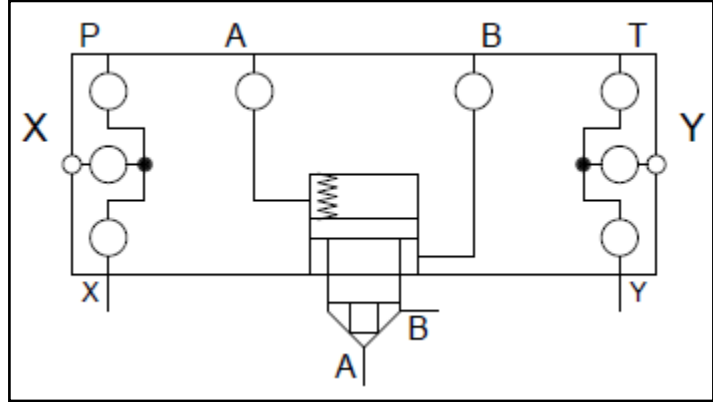
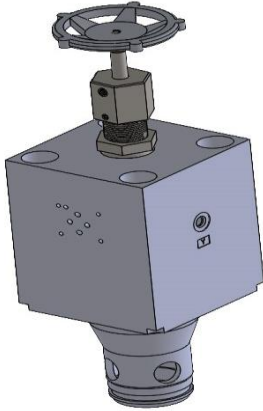

- ✓ Standard ISO & DIN 23432 cavity & porting
- ✓ Adjustable stroke-limiting for decreasing the traveling distance of the logic valve
- ✓ Set screws for locking
- ✓ Control areas provide fast response time
- ✓ Can close poppet under high load pressure
- ✓ Allows pilot-to-open/pilot-to-close
- ✓ Proportional option without feedback

Applications

Stroke Limiting Active Directional Control Poppet

The active directional control poppet is pilot-operated to cut off the main hydraulic supply to the circuit. The directional control valve regulates when the poppet is open or closed. The directional control D03 valve can receive the pilot pressure internally or externally. The D03 valve can also be internally or externally drained.

The active directional control poppet can be used in a variety of applications, including: prefill valve, pilot-operated check, proportional flow control valve, etc.

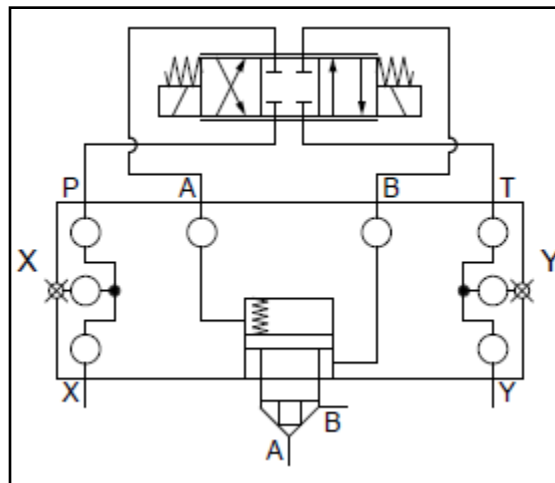
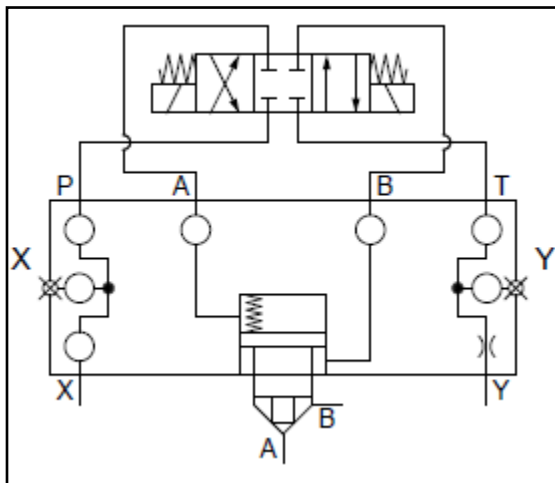

Left: Active directional control poppet & cover with a D03 valve

Right: Active directional control poppet & cover with a proportional D03 valve

General Layout

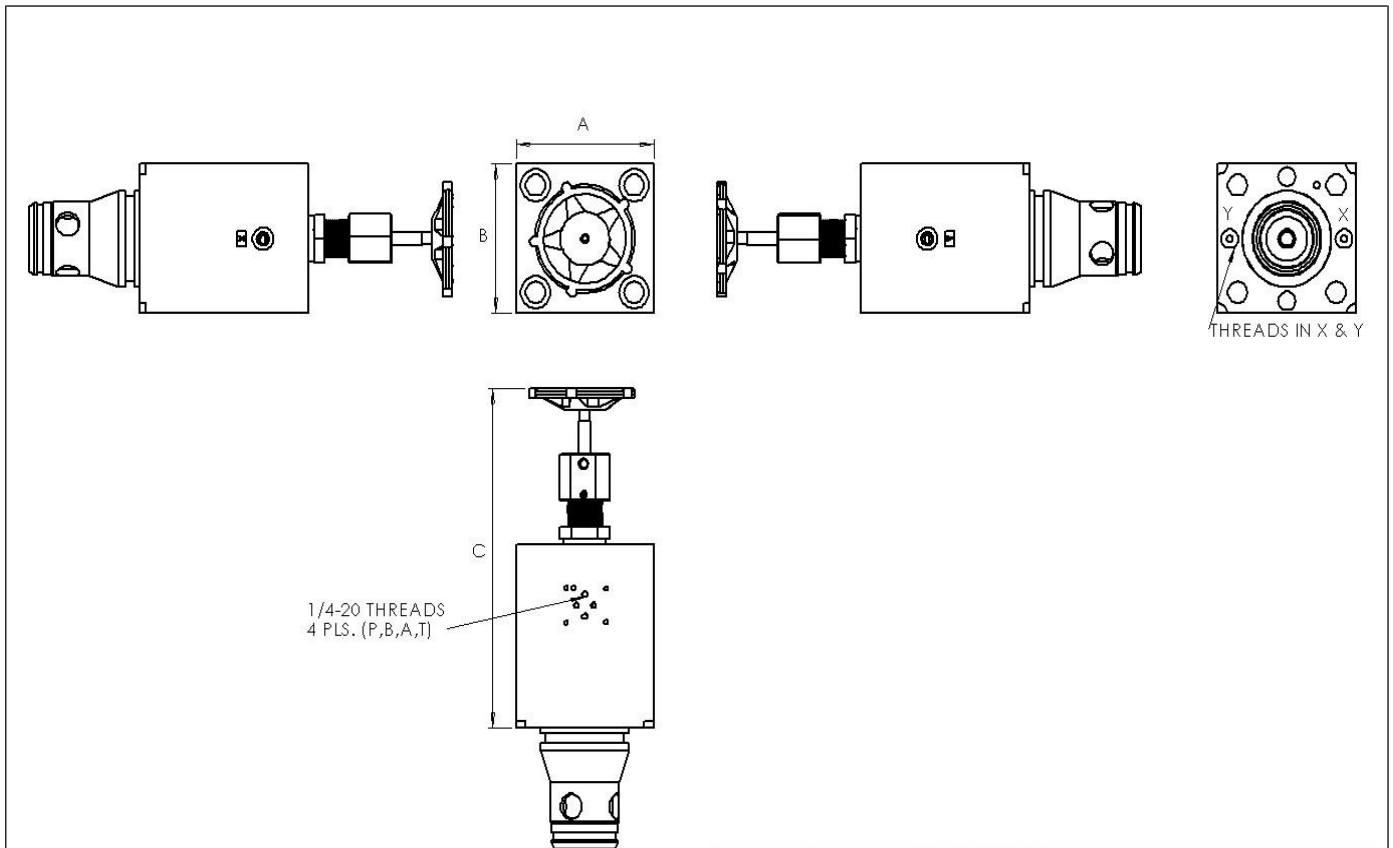

Sizes 16 mm to 50 mm

Cover Size	Flow	A	B	C	External X & Y Port Sizes	Threads in Internal X & Y	Bolts
16 mm	80 GPM	2.75"	3.00"	6.30"	SAE# 4	1/4-20 UNC	5/16-18 X 3.50"
25 mm	100 GPM	3.50"	3.50"	8.00"	SAE# 4	1/4-20 UNC	1/2-13 X 4.00"
32 mm	200 GPM	4.00"	4.00"	8.00"	SAE# 4	1/16-27 NPT	5/8-11 X 4.00"
40 mm	350 GPM	5.00"	5.00"	10.50"	SAE# 4	1/16-27 NPT	3/4-10 X 5.00"
50 mm	450 GPM	5.50"	5.50"	12.25"	SAE# 4	1/16-27 NPT	3/4-10 X 6.75"

Order Code _____

AMT-ACTD03-PSTK**_**

Almo
Manifold
& **T**ool

Active poppet & cover
with **D03** interface

Size: **16**, **25**, **32**, **40**, or **50** mm

BL = Include bolts at extra charge

Blank = Customer will supply bolts

DIN 24342 MONITORED ACTIVE POPPET

SIZES 16 mm TO 50 mm

6000 PSI

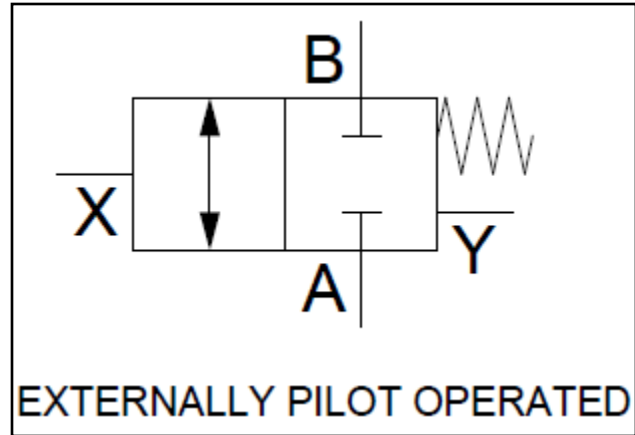

- ✓ Standard ISO 7368 & DIN 24342 cavity & porting
- ✓ Control areas provide fast response time
- ✓ Can close poppet under high load pressure
- ✓ Built-in limit switch provides position feedback of main cartridge, AC or DC

Applications

Monitored Active Poppet

The monitored active poppet serves to add required protection for clamp circuits. This poppet is pilot-operated to cut off the main hydraulic supply to the clamp circuit. It is also used or control press closing.

The monitored active poppet can meet ISO 13849-1 PLd (Safety Cat. 3) & ISO 13489 PLe (Safety Cat. 4) when used properly.

Contact our engineering department to discuss your safety application needs.

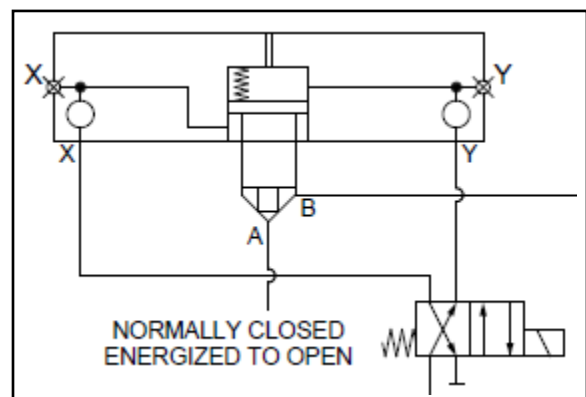
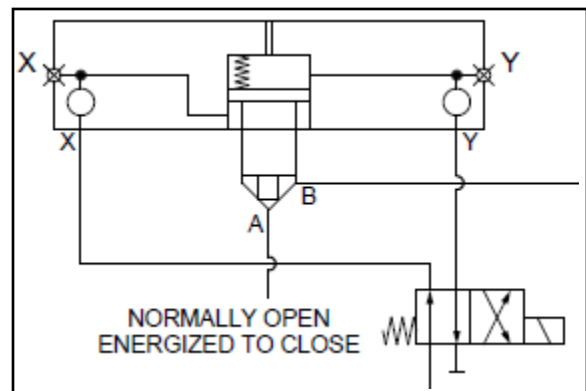

General Layout

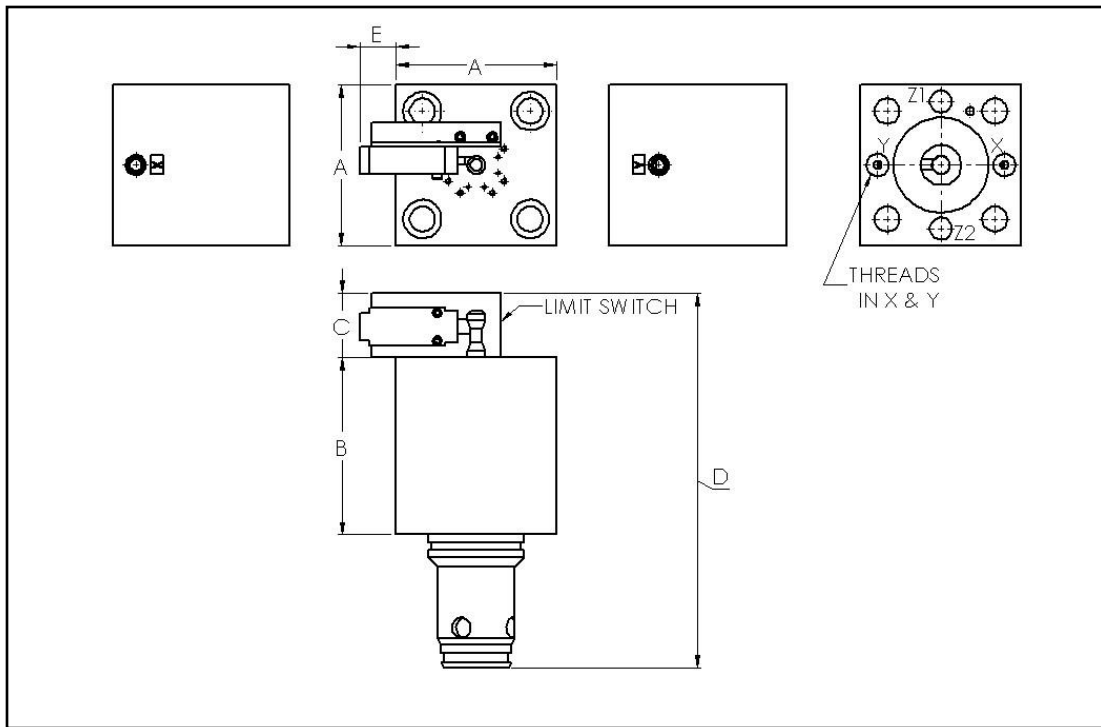

Sizes 16 mm to 50 mm

Cover Size	Flow	A	B	C	D	E	External X & Y Port Sizes	Internal X & Y Threads	Bolts
16 mm	80 GPM	2.75"	3.46"	2.00"	7.664"	2.00"	1/16-27 NPT	1/4-20 UNC	5/16-18 X 3.50" (4)
25 mm	100 GPM	3.50"	3.76"	2.00"	8.5"	2.00"	1/16-27 NPT	1/4-20 UNC	1/2-13 X 3.50" (4)
32 mm	200 GPM	4.00"	4.00"	2.00"	9.5"	2.00"	1/16-27 NPT	1/4-20 UNC	5/8-11 X 4.00 (4)
40 mm	350 GPM	5.00"	5.50"	2.00"	11.633"	2.00"	SAE# 4	1/16-27 NPT	3/4-10 X 5.00" (4)
50 mm	450 GPM	5.50"	6.25"	2.00"	13.047"	2.00"	SAE# 4	1/16-27 NPT	3/4-10 X 6.50" (4)

Order Code

AMT-MAP-**-*_**

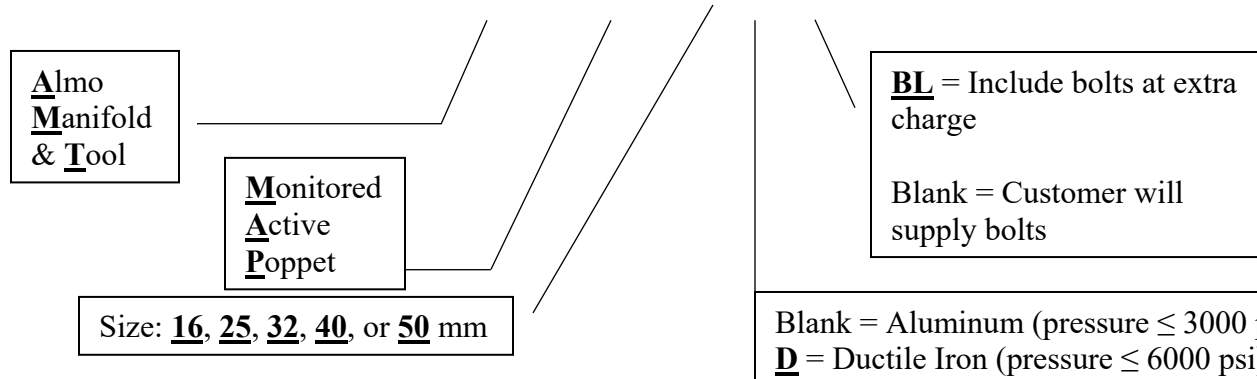

NOTES:

COUNTERBALANCE VALVES

DIN 24342 HIGH FLOW COUNTERBALANCE

SIZES 32 mm TO 50 mm

6000 PSI

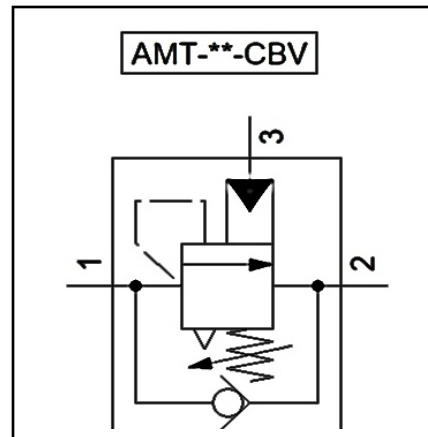

- ✓ Standard ISO 7368 & DIN 24342 cavity & porting
- ✓ Available with or without Inline Cavity Block
- ✓ Prevent unintended or uncontrolled movement of static or dynamic loads
- ✓ Offers greater stability to the machinery
- ✓ Control the load speed in case of hydraulic hose failure
- ✓ Suitable for safe and stable load handling

Applications

High flow Load Holding Counterbalance

Counterbalance valves are also known as load holding valves because of its ability to hold heavy loads. The load holding capacity is achieved by allowing free flow into the cylinder/actuator and by blocking the reverse flow until a pilot pressure inversely proportional to the load is applied. In short, the counterbalance valve permits flow in one direction and block the flow opposite to it. Counterbalance valves are well suited for clamping applications and it avoids falling of negative loads when any failures occur. The counterbalance valve functions are similar to that of flow control valves and are used for high-speed safe lowering/elevation of loads. Load holding, load control and load safety are the three important **counterbalance valve functions**. The counterbalance valve prevents unintended motion of actuators/cylinders holding heavy loads. These valves will help to stabilize the load, avoid damage of equipment and eliminate dangers caused as a result of the hose failures. For aerial work platforms, it is necessary to prevent sudden or unwanted downward drifts. Even under the inoperable conditions, these valves will hold the load firmly against the gravitational force by applying a back pressure against the load. Under operating conditions, the load can be elevated by passing fluid through the check valve. Also, this valve will prevent uncontrolled or unsafe motion of loads as a result of line breaks or overloads.

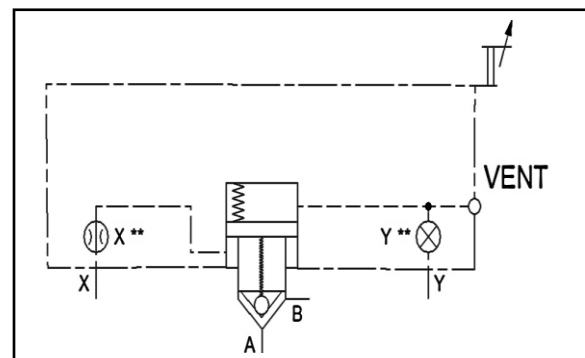

General Layout

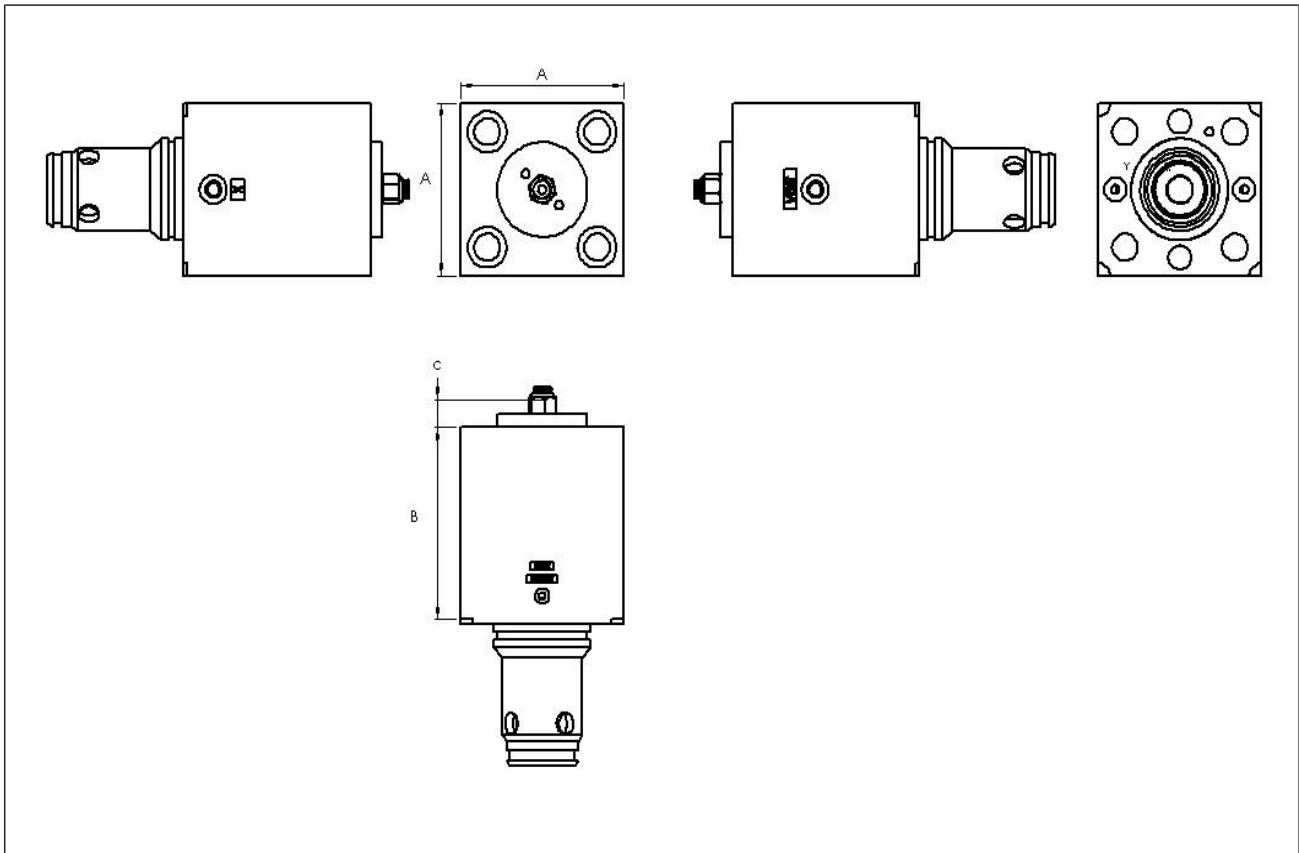

Sizes 32 mm to 50 mm

Cover Size	Flow	A	B	C	External Port Size	Internal X Port size	Bolts
32 mm	200 GPM	4.00"	5.40"	1.13"	SAE #4	1/16-27 NPT	5/8-11 X 5.50" (4)
40 mm	350 GPM	5.00"	6.47"	1.13"	SAE #4	1/16-27 NPT	3/4-10 X 6.25" (4)
50 mm	450 GPM	5.55"	6.915"	1.13"	SAE #4	1/16-27 NPT	3/4-10 X 6.25" (4)

Order Code

AMT-CBV-**-**

Almo
Manifold
& **T**ool

Counter
Balance
Valve

Size: 32, 40, or 50 mm

BL = Include bolts at extra charge
Blank = Customer will supply bolts

Pressure Drop vs. Flow Rate for CBV32 Freeflow and Counterbalance

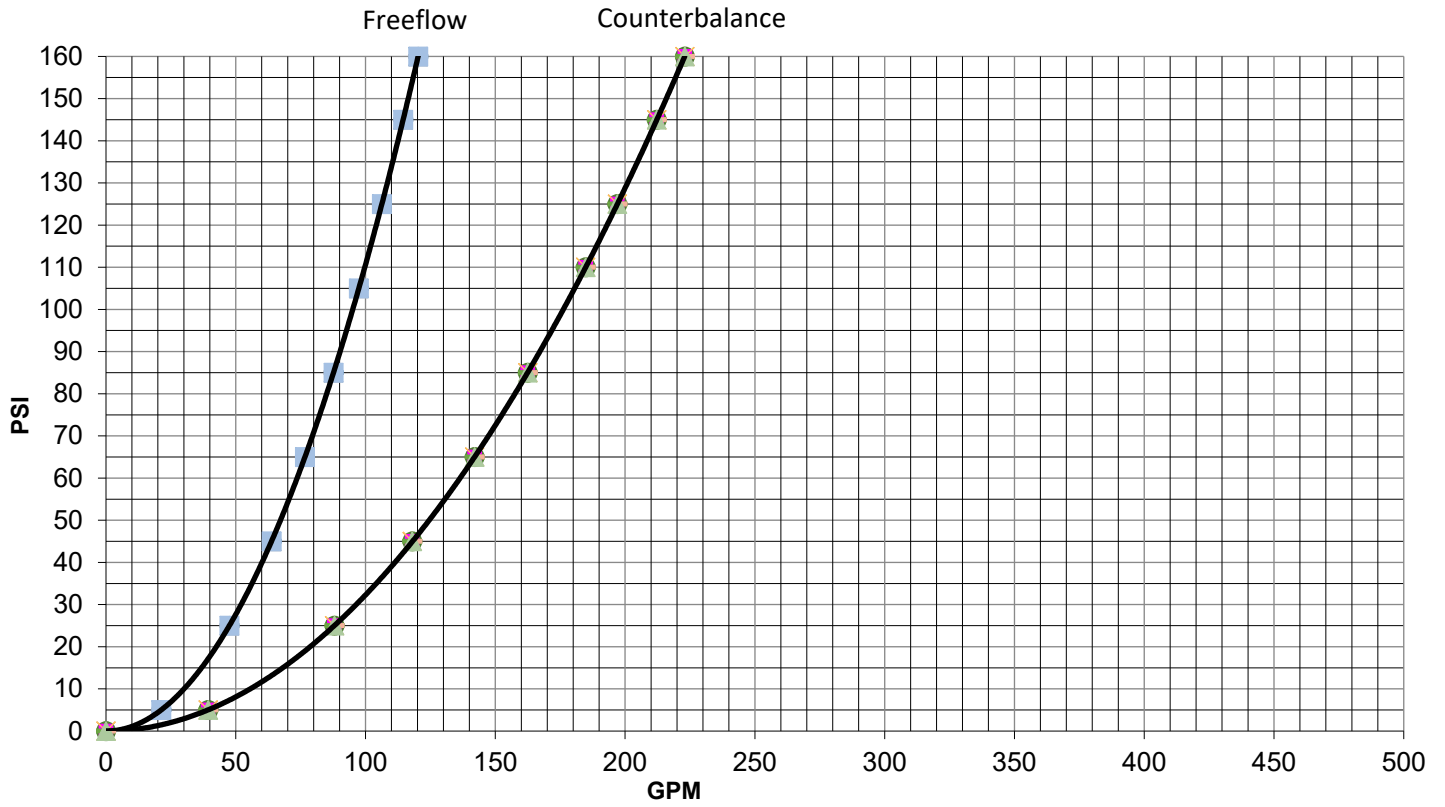

Pressure Drop vs. Flow Rate for 40mm Freeflow and Counterbalance

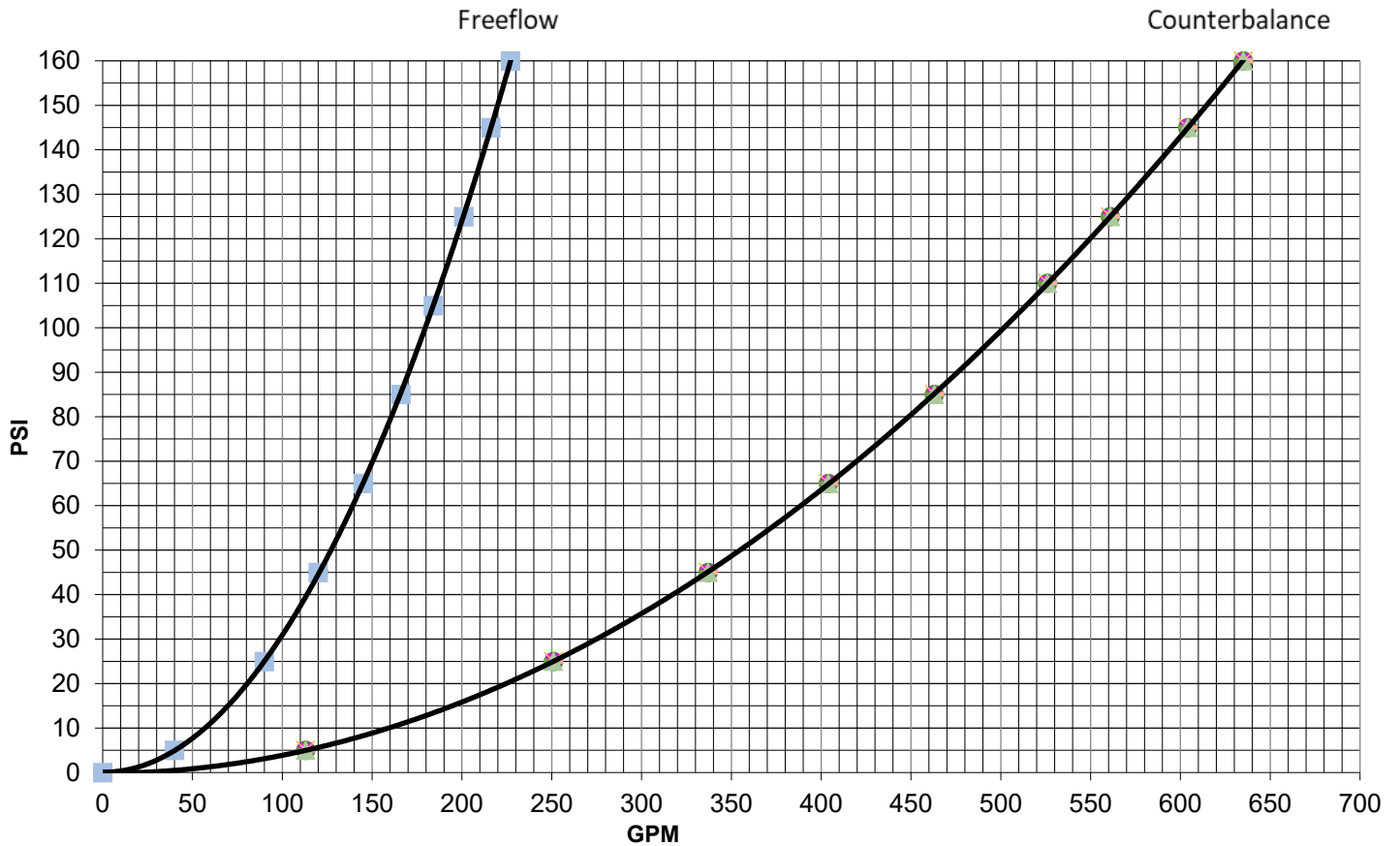

Pressure Drop vs. Flow Rate for 50mm Freeflow and Counterbalance

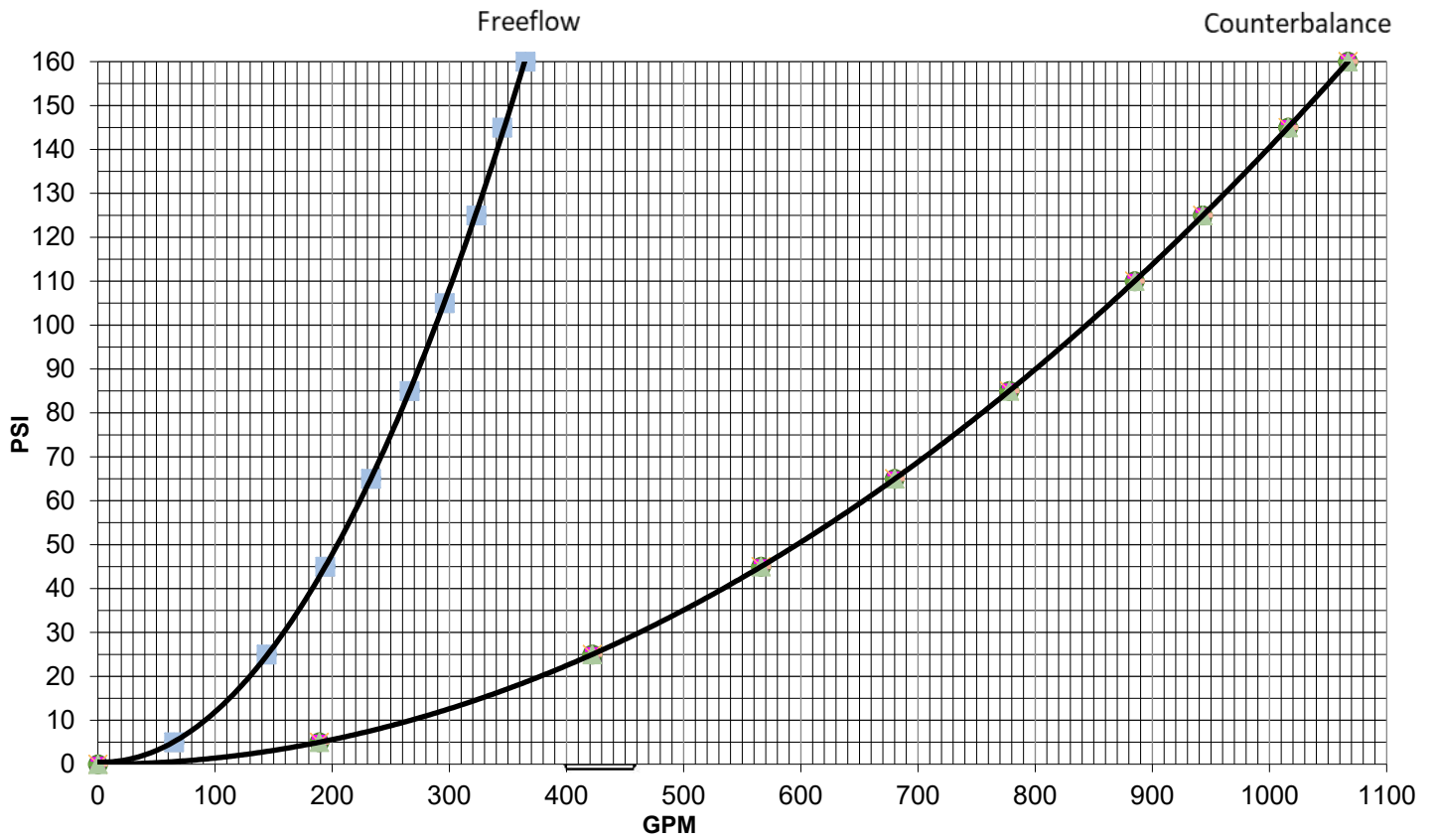

NOTES:

PROPORTIONAL FLOW CONTROL VALVE

DIN 24342 PROPORTIONAL FLOW CONTROL

SIZES 16 mm TO 50 mm

6000 PSI

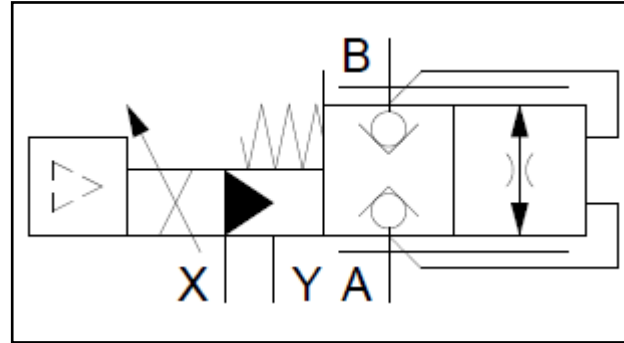

- ✓ Standard ISO 7368 & DIN 24342 cavity & porting
- ✓ Control areas provide 4 milliseconds response time
- ✓ Can close poppet under high load pressure
- ✓ Controlled by on-board electronics
- ✓ Reference signal options: voltage or current

Specifications

Proportional Flow Control Valve

The proportional flow control valve is a fail-close valve, which means that if its requirements are not met, the valve will close. The valve is controlled by on-board electronics.

The on-board electronics consists of a 4-way, 3 position + fail-safe position, servo-proportional valve, a digital amplifier (driver), and a transducer. The digital amplifier is attached to the servo-proportional valve. The servo-proportional valve connects to the transducer, which is connected to the proportional flow control valve by a LVDT rod. The proportional flow control valve and cover assembly is shown on pg. 51.

Note: The proportional flow control valve assembly does not come with the adapter/connector.

Note: FC stamped on the on-board amp plate stands for fail close.

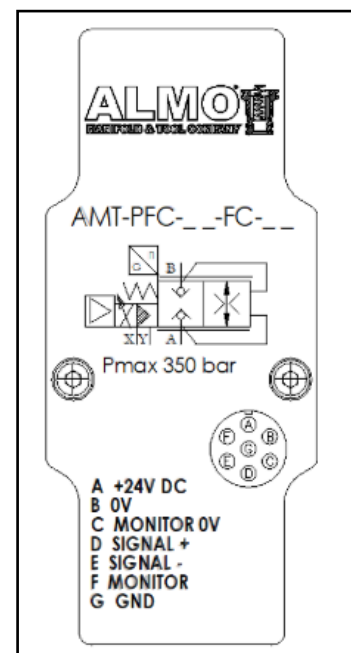

Proportional Flow Control Valve Specifications (Continued)

General Layout

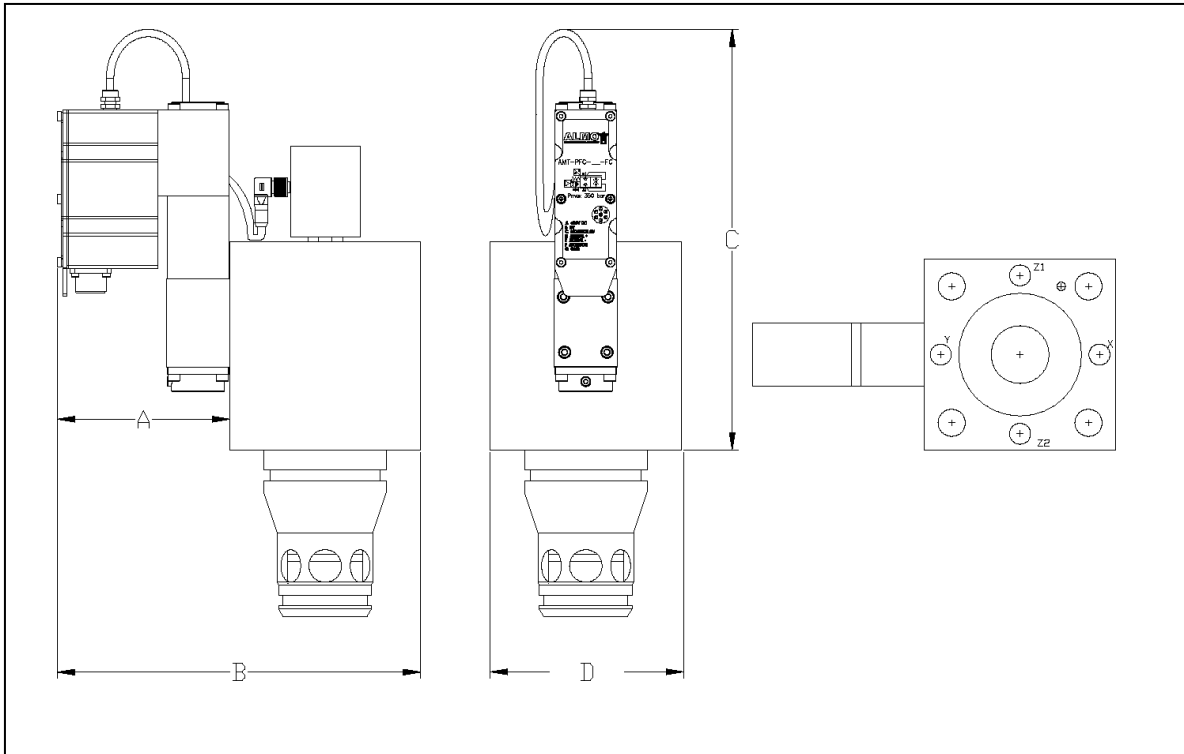

Sizes 16 mm to 50 mm

Cover Size	A	B	C	D	Bolts
16 mm	4.85"	7.85"	11.76"	2.75"	5/16-18 X 5.75" (4)
25 mm	4.85"	8.43"	11.76"	3.50"	1/2-13 X 5.75" (4)
32 mm	4.85"	8.93"	11.76"	4.00"	5/8-11 X 6.00" (4)
40 mm	4.85"	9.93"	11.76"	5.00"	3/4-10 X 6.00" (4)
50 mm	4.85"	10.35"	11.76"	5.55"	3/4-10 X 6.00" (4)

Order Code

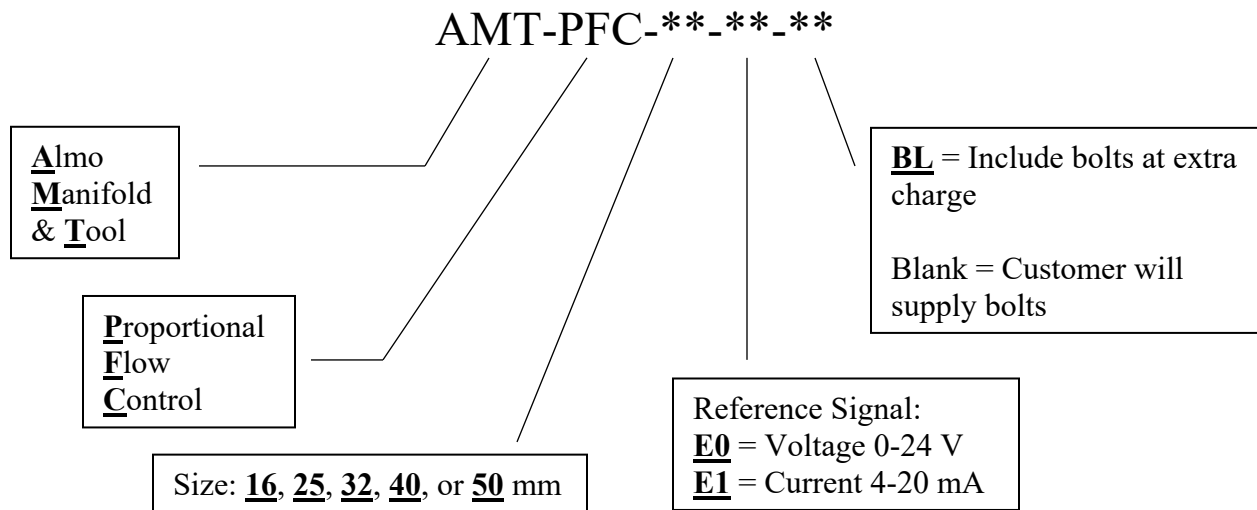

The digital amplifier controls all the functions for the whole proportional flow control valve assembly. The transducer sends a signal to the digital amplifier that tells the digital amplifier how far open the proportional flow control valve is in relation to the servo-proportional valve. The digital amplifier will then control how much farther the proportional flow control valve will open. The settings for the digital amplifier are set at Almo so that it is ready for operation when the valve arrives.

Voltage Reference Signal – E0 Option

For this option, all you need to provide is a 0-10-volt command, which is proportionate to the position of the valve. No additional amplifier card is needed. The valve requires a 24-volt supply with a minimum electrical current of 3 amps per valve. It also must have a minimum pilot pressure of 40 psi. If the voltage or pressure drops below the minimum requirement, the valve shifts closed to safe mode. There is more information about this option of the next page.

Current Reference Signal – E1 Option

You will need to provide a 4-20 mA command for this option, which is proportionate to the position of the valve. No additional amplifier card is needed. The valve must have a 24-volt supply with a minimum electrical current of 4 mA per valve. It also requires a minimum pilot pressure of 40 psi. The valve will shift closed (safe mode) if the voltage or pressure drops below the minimum requirement. The next page has more information about this option.

Repeatability 0.1%

Hysteresis 0.2%

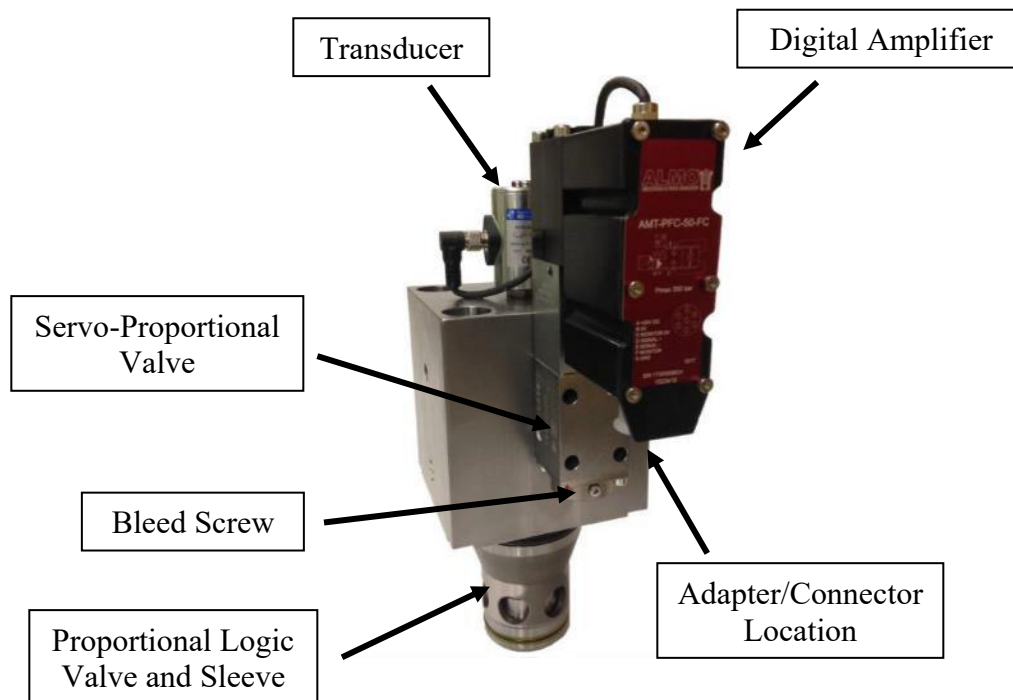

Note: Oscillation may occur during initial startup/maintenance. To provide more stability, bleed the air out of the bleed screw on D03 of the servo-proportional valve (see above image). Please contact the engineering department if more technical support is required.

Proportional Flow Control Valve Performance Curves

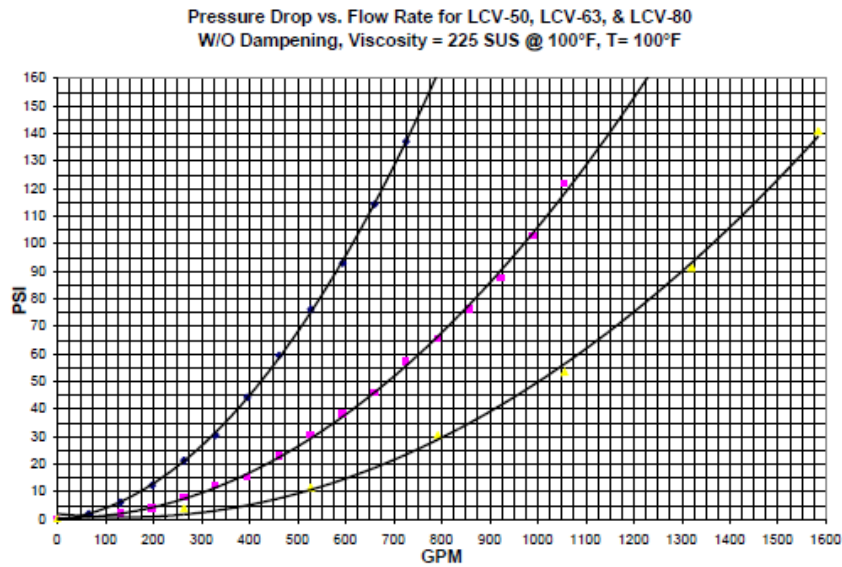
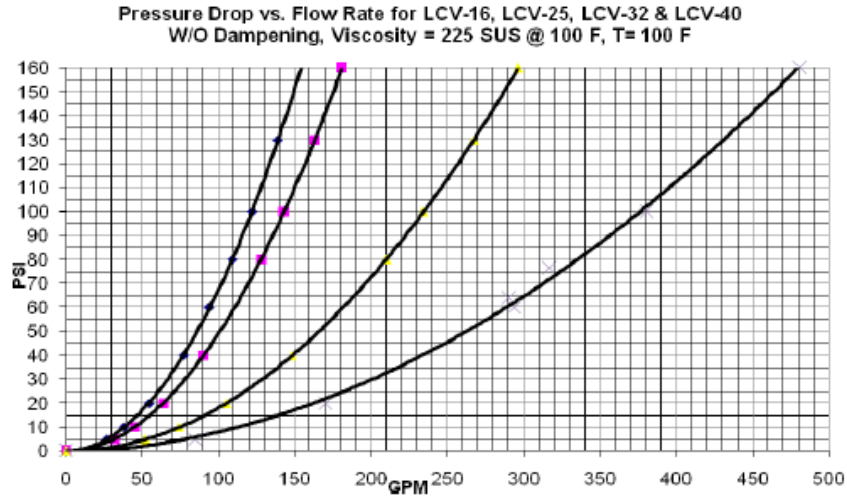

Proportional Flow Control Valve Application Data

All pressure drops shown on this page and the following page are based on 170 SUS fluid viscosity and 0.87 specific gravity. For any other specific gravity (G1), the pressure drop (ΔP) will be approximately $\Delta P = \Delta P (G1/G)$. See the chart below for other viscosities.

Fluid	cSt	10	14.5	32	36	43	54	65	76	86	108	216	324	400
Viscosities	SUS	60	75	150	170	200	250	300	350	400	500	1000	1500	1900
	Mutliplier	0.77	0.81	0.97	1.00	1.04	1.10	1.15	1.20	1.24	1.31	1.56	1.72	1.83

Use mineral oil-based hydraulic fluids HL or HM type, according to ISO 6743-4. For these fluids, use NBR seals. For fluids HFDR type (phosphate esters), use FPM seals (code G). For the use of other kinds of fluids, such as HFA, HFB, and HFC, please contact our technical department.

Note: Using fluids at temperatures $>180^{\circ}\text{F}$ can damage the seals more quickly, as well as, cause degradation of the fluid's physical and chemical properties. For safety, temperatures $>130^{\circ}\text{F}$ are not recommended.

Proportional Flow Control Valve Performance Curves (Continued)

The following curves obtained with mineral oil viscosity of 170 SUS (36 cSt) at 122°F (50°C) and dedicated OBE.

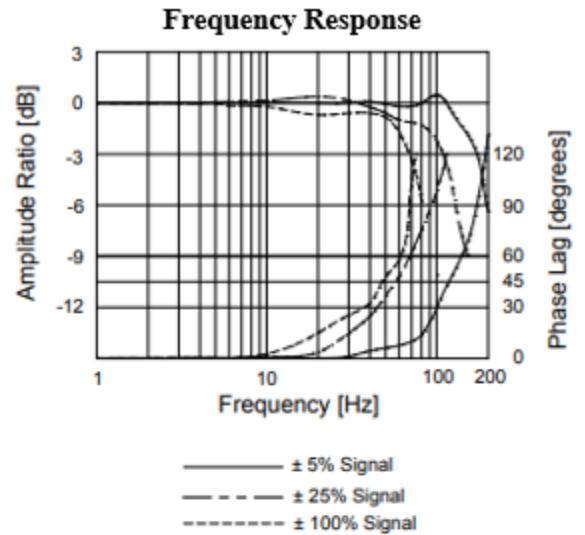
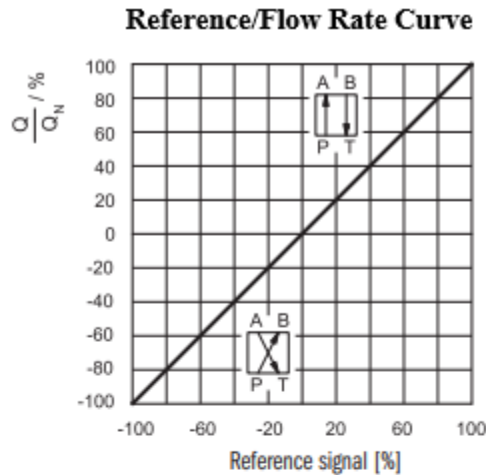

Typical flow rate curves at constant $\Delta p = 70$ bar P-T, according to the reference signal.
 Note: With positive reference signal connected to pin D, the valve regulates P-A/B-T.

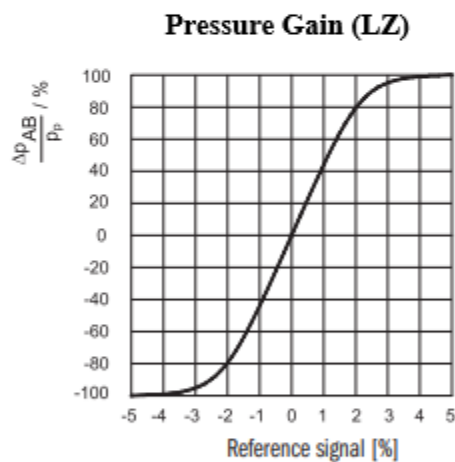

The diagram above states the maximum valve-controlled flow rate according to the pressure drop between the P and T ports.

The diagram shows the valve pressure gain expressed as percentage of the ratio between the port pressure variation in A or B (Δp_{AB}) and the P system pressure, according to the reference signal. In practice, the pressure gain states the valve reaction towards external disturbances aimed at changing the actuator position.

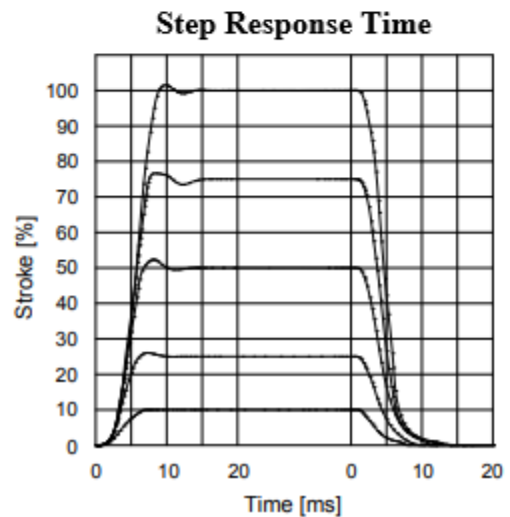
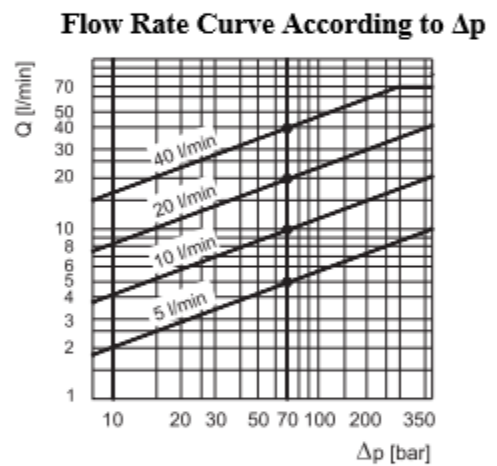

Due to inherent phase lag characteristics of the overall system and machine, common industrial control practices recommend, as rule of thumb, to utilize the phase lag frequency ratings of 45° or less when applying Servo and Proportional valves to any position control loop for stable, repeatable, and consistent control.

Proportional Flow Control Valve Specifications (Continued)

Voltage Reference Signal – E0

For this option, the command signal required is 0-10 volts. The monitor signal is also 0-10 volts, which is available 0.5 seconds after the card is powered on OBW/OBM.

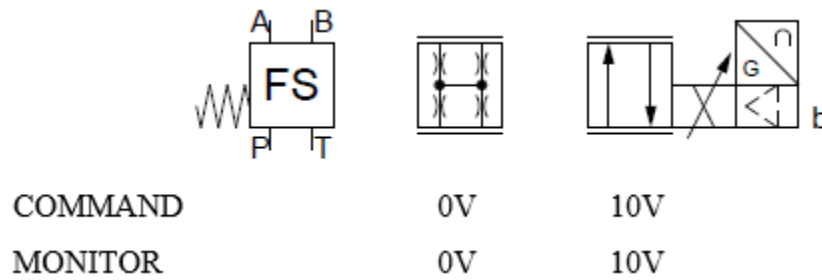

Pin	Valve	OBC	OBW	OBM
A	24 V DC	Supply voltage		
B	0 V			
C		Enable 24 V DC	Not used -	Pin F reference 0 V
D	0-10 V	Command (differential input)		
E	0V	Pin D reference		
F	0-10 V	Monitor (0 V reference: pin B)		Monitor
PE	GND	Ground (Earth)		

Current Reference Signal – E1 Option

For this option, the command signal required is 4-20 mA. If the current drops below 4 mA, the card will shut down until the applied signal is back in the range of 4-20 mA and is available 0.5 seconds after the card is powered on OBW/OBM.

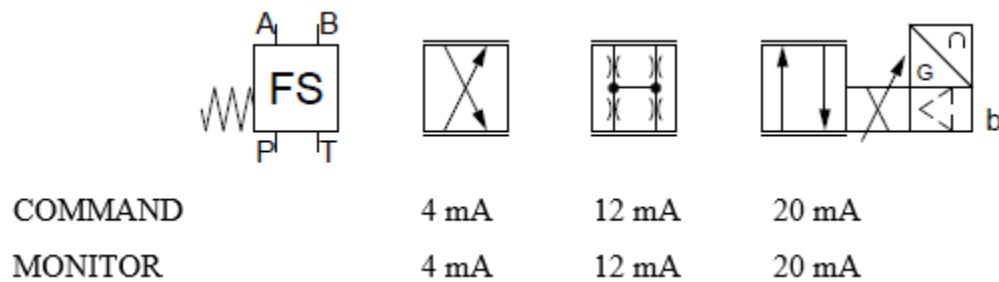

Pin	Valve	Version A	Version B	Version C
A	24 V DC	Supply voltage		
B	0 V			
C		Enable 24 V DC	Not used -	Pin F reference 0 V
D	4-20 mA	Command (differential input)		
E	0 V	Pin D reference		
F	4-20 mA	Monitor (0 V reference: pin B)		Monitor
PE	GND	Ground (Earth)		

NOTES:

SINGLE DIN CAVITY BLOCKS

SINGLE DIN CAVITY BLOCKS (ALMO "UCB" BLOCKS)

SIZES 16 mm TO 63 mm

6000 PSI



- Our single DIN 24342 cavity manifolds offer pilot circuit flexibility simply by rotating the valve cover 90°. The four active locating positions & pilot port designations are shown below, along with the general layout & dimensional specifications.
- Each manifold will be supplied with 4 plugs for the valve face, 2 NPT plugs for internal plumbing, & 3 SAE plugs for ports 1, 2, & 3. None of these plugs are installed upon shipment.

Dimensions

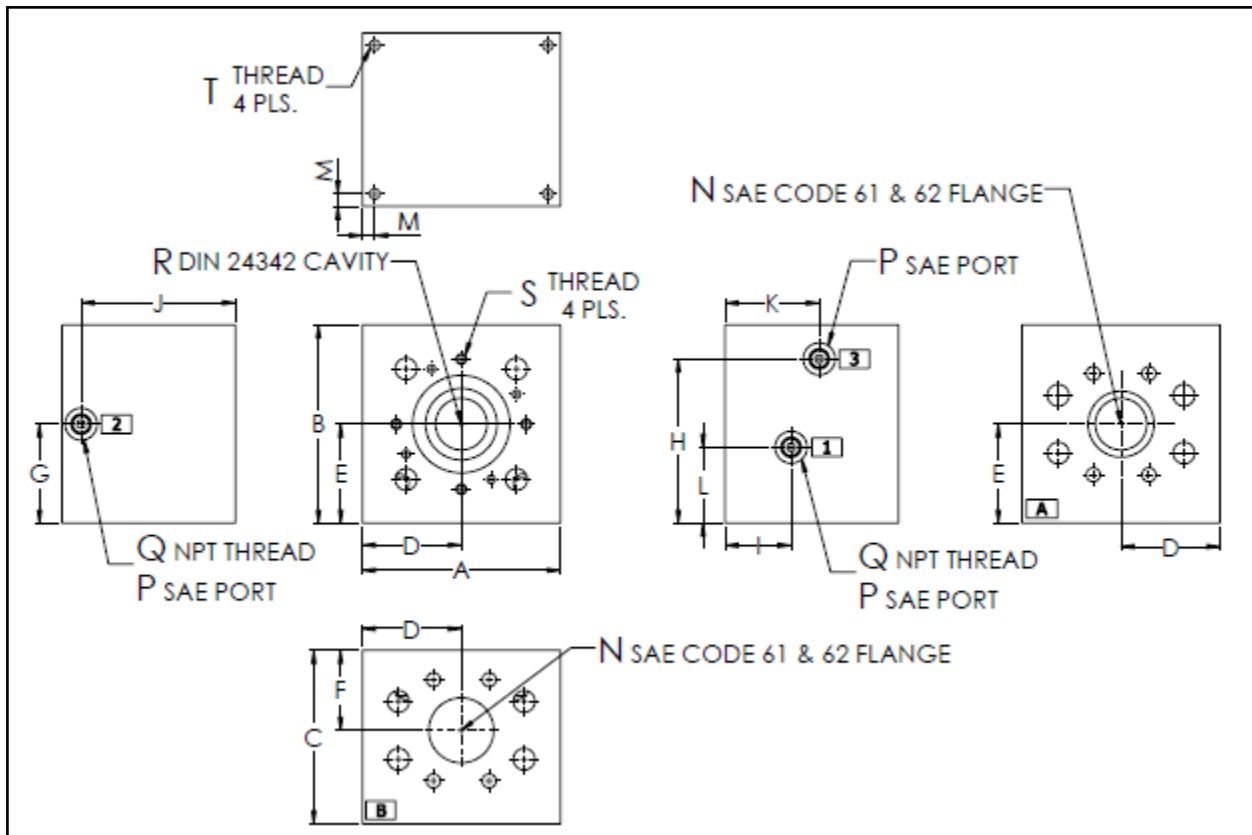

DIMENSIONAL SPECIFICATIONS IN INCHES

'R' DIN Size	A	B	C	D	E	F	G	H	I	J	K	L	M
16 mm	3.25	3.25	3.38	1.63	1.63	1.39	1.63	2.68	1.39	2.88	1.39	0.75	0.30
25 mm	4.00	4.00	4.00	2.00	2.00	1.64	2.00	3.30	1.50	3.25	2.13	1.50	0.38
32 mm	5.00	5.00	4.50	2.50	2.50	1.98	2.50	4.15	1.68	3.88	2.37	1.73	0.38
40 mm	6.00	6.00	5.25	3.00	3.00	2.42	3.00	4.98	2.00	4.68	2.85	2.30	0.38
50 mm	7.00	7.00	6.25	3.50	3.50	2.73	3.50	5.90	2.25	5.58	3.58	2.50	0.50
63 mm	9.00	9.00	7.50	4.50	4.50	3.53	5.25	8.33	3.00	6.75	4.13	3.75	0.63

DIMENSIONAL SPECIFICATIONS IN INCHES

'R' DIN Size	'N' Code 61 & 62 Flange	'P' Port Size	'P' Thread	'Q' Thread	'S' Thread	'T' Mounting Thread
16 mm	1.00"	SAE #4	7/16-20 UNF	1/16-27 NPT	10-24 UNC	3/8-16 UNC
25 mm	1.25"	SAE #4	7/16-20 UNF	1/16-27 NPT	1/4-20 UNC	3/8-16 UNC
32 mm	1.50"	SAE #6	9/16-18 UNF	1/16-27 NPT	1/16-27 NPT	3/8-16 UNC
40 mm	2.00"	SAE #6	9/16-18 UNF	1/16-27 NPT	1/16-27 NPT	3/8-16 UNC
50 mm	2.50"	SAE #8	3/4-16 UNF	1/8-27 NPT	1/8-27 NPT </td <td>1/2-13 UNC</td>	1/2-13 UNC
63 mm	3.00"	SAE #8	3/4-16 UNF	1/8-27 NPT	1/8-27 NPT	5/8-11 UNC

Circuit Options

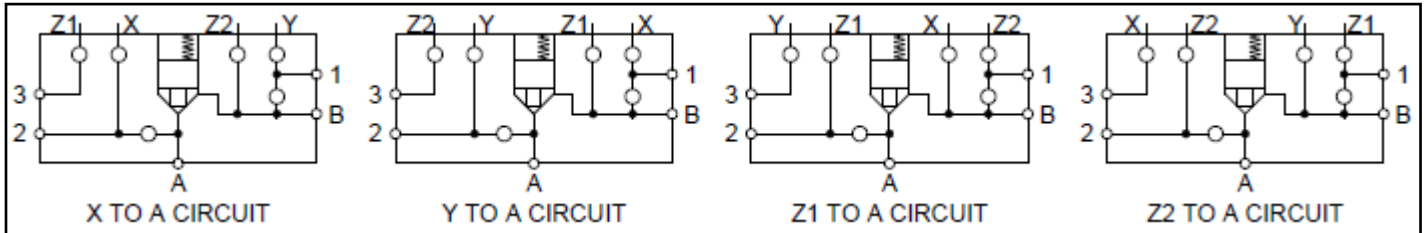

Installation

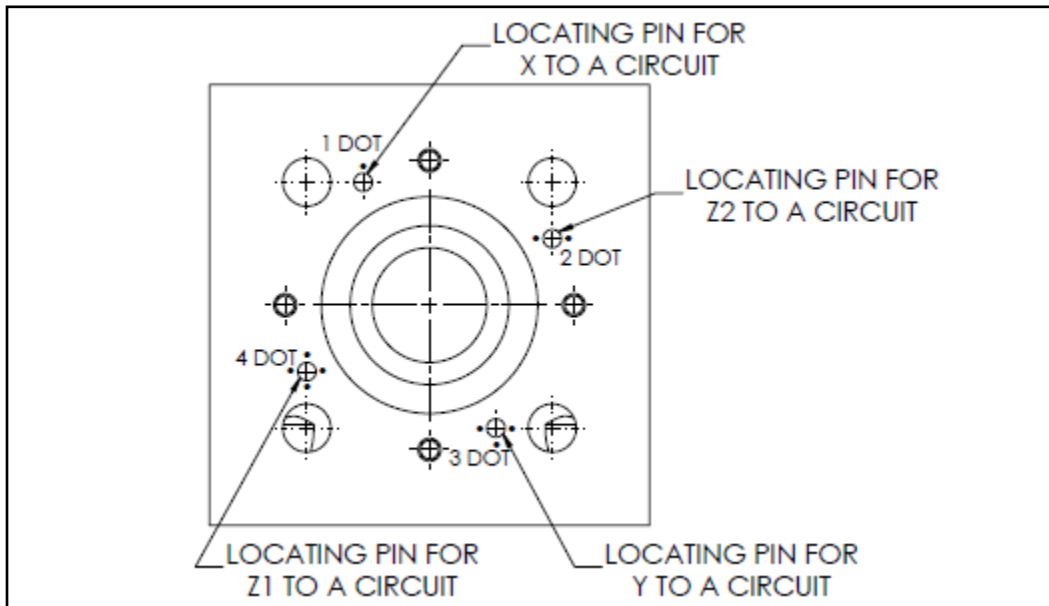

Order Code

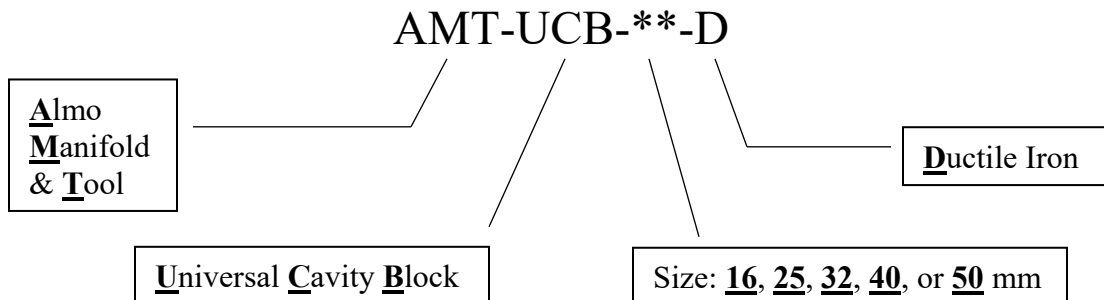

80 MM DIN CAVITY BLOCK

3000 PSI OR 6000 PSI OPTION



- Our single DIN 24342 80 mm cavity manifold offers pilot circuit flexibility simply by rotating the valve cover 90°. The four active locating positions & pilot port designations are shown below, along with the general layout & dimensional specifications.
- This manifold will be supplied with 4 plugs for the valve face, 2 NPT plugs for internal plumbing, & 3 SAE plugs for ports 1, 2, & 3. None of these plugs are installed upon shipment.

Dimensions

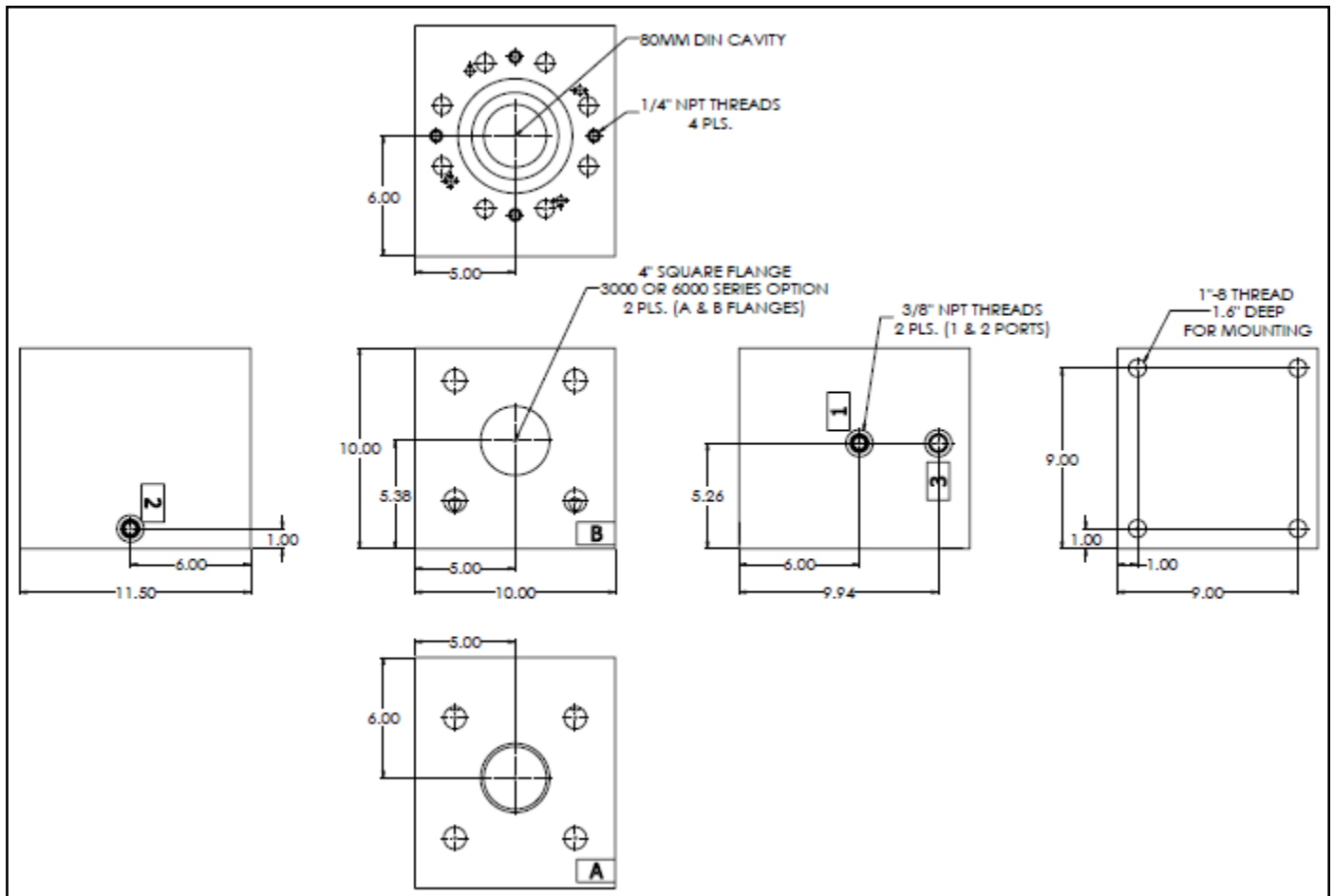

Circuit Options

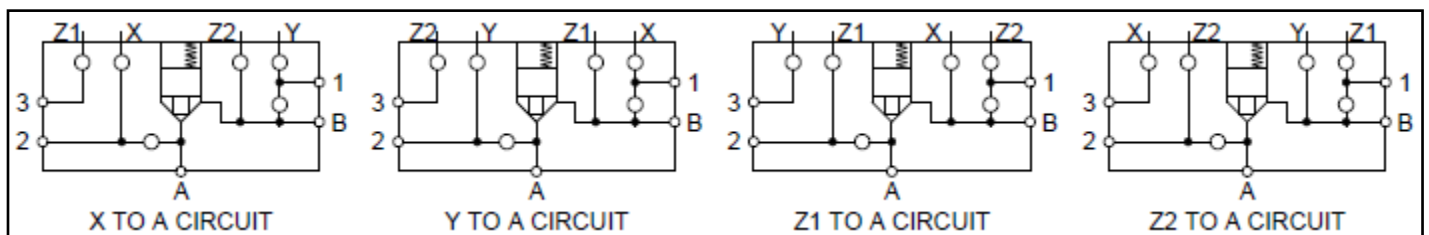

Flange Options

3000 Series Flange Option

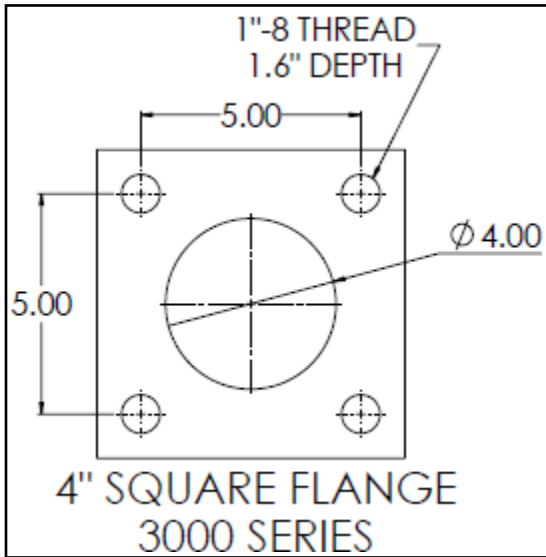

6000 Series Flange Option

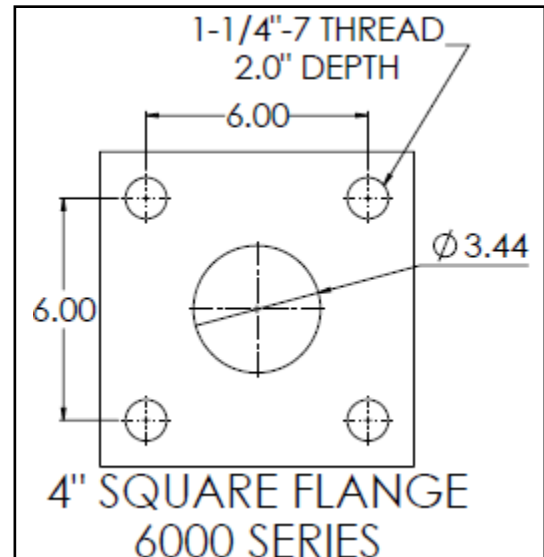

Installation

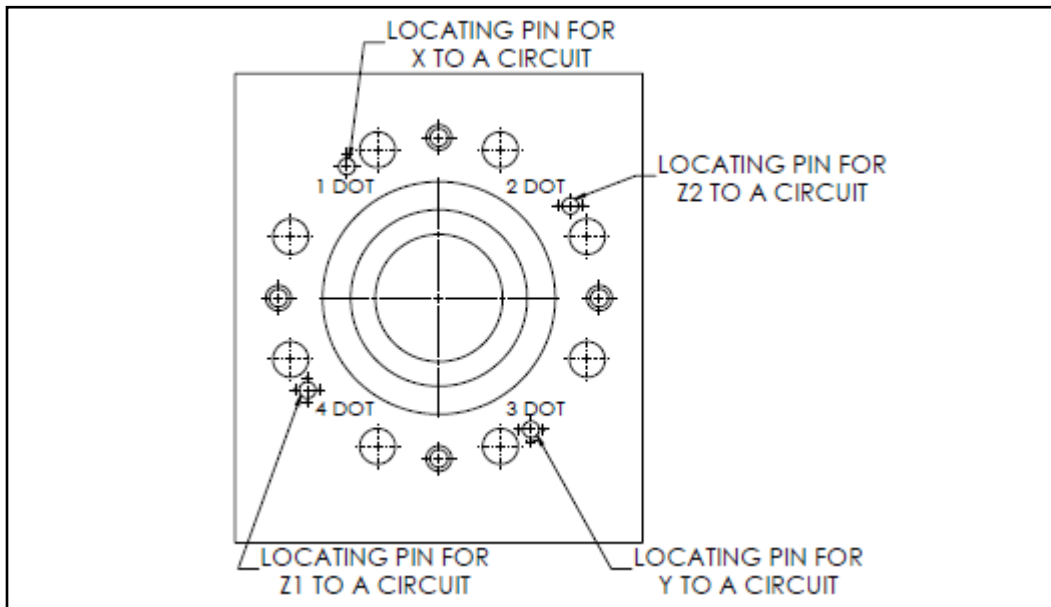

Order Code

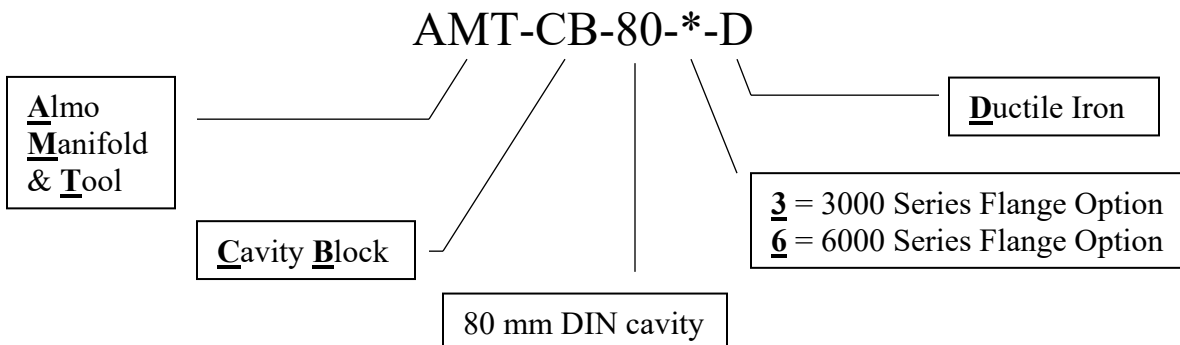

NOTES:

HIGH LOW WITH
REGEN CIRCUIT
MANIFOLD
ASSEMBLY

HIGH LOW WITH REGEN CIRCUIT MANIFOLD ASSEMBLY

SIZES 16MM TO 63MM | 0-6000 PSI

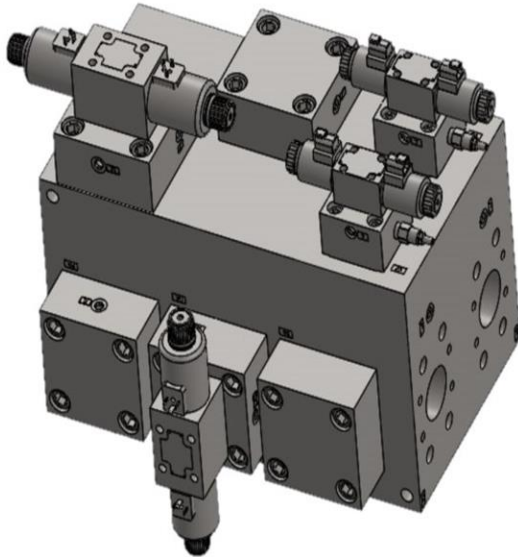

- Standard universal Code 61 & 62 flanges. Custom flanges and ports are available.
- P1- High discharge, Low pressure pump (0-to 3000 PSI.)
- P2- Low discharge, High pressure pump (0-to 6000 PSI.)
- V6-V7 Unloading relief function de-energized vents flow to tank, for zero start up pressure on pumps
- Regenerative circuit speeds extension stroke by 5.3 %, Decreases power consumption, reduces cycle time, and increases productivity.

Schematic

DELTA P ADVANTAGE

Utilizing Almo slip-in cartridge valves provides high flow and low pressure drop design for an energy efficient hydraulic circuit.

A Regenerative circuit is a system that is used to speed up the extension stroke of a double acting single rod cylinder. The output is connected to the input in the directional control valve. By this concept, increase of the velocity of the piston and decrease in the cycle time. The high-low in this circuit is used to provide two Output speeds. P1 is set at a low value, P2 is high. At low system pressure, P1 and P2 are not active, the flow to the system is the sum of both pumps, As the system pressure approaches P1, pump P1 is unloaded at the relief valve and only flow from pump P2 is delivered to the actuator. Thus, we have high flow rates at low pressure and low flow rates at high pressure.

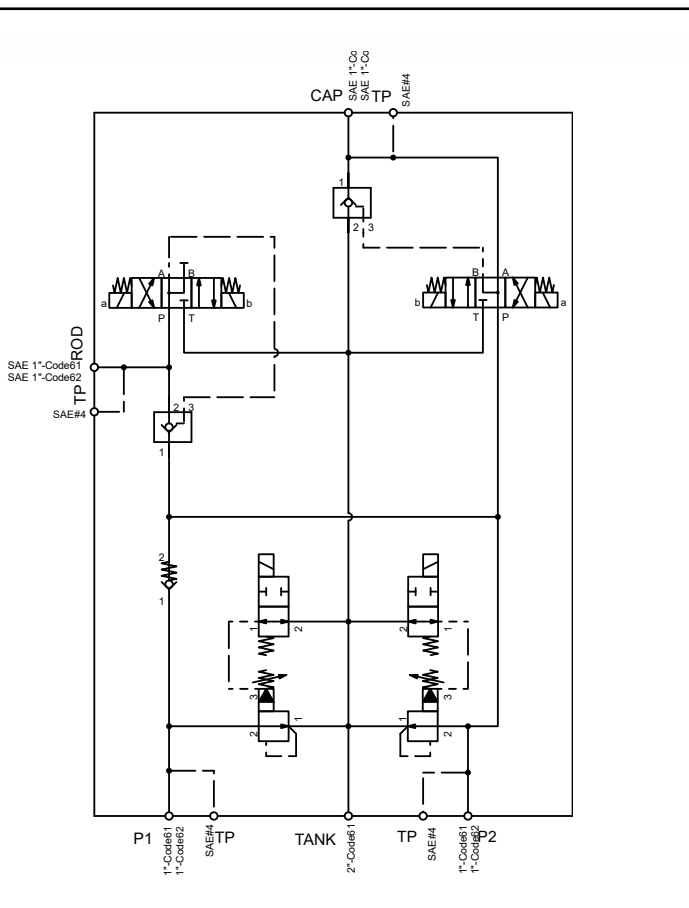

General Layout

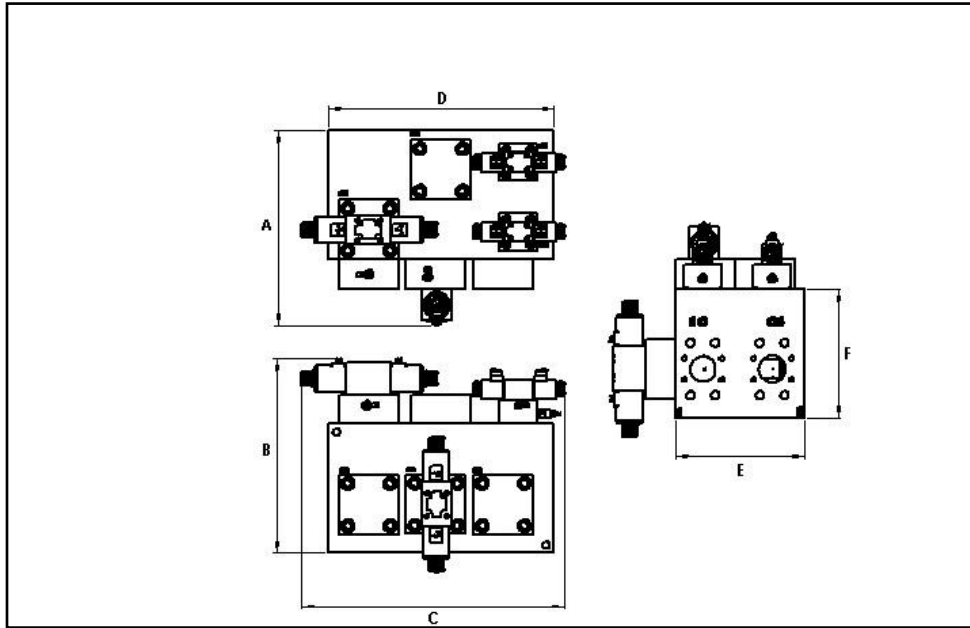

Size	A	B	C	D	E	F	TANK PORT	PRESSURE PORTS	DRAIN
16mm	10.92"	11.89"	12.75"	10.00"	6.53"	6.53"	2.00"	1.00"	SAE #6
25mm	11.84"	12.42"	15.11"	13.00"	7.03"	7.03"	2.00"	1.25"	SAE #6
32mm	13.38"	14.76"	17.83"	15.00"	8.50"	8.50"	2.00"	1.50"	SAE #6
40mm	15.23"	15.28"	20.65"	19.00"	10.0"	10.0"	3.50"	2.0"	SAE#10
50mm	18.16"	18.16"	24.46"	21.00"	12.0"	12.0"	3.50"	2.5"	SAE#10
63mm	20.61"	22.01"	27.20"	25.50"	13.83"	14.43"	3.50"	2.5"	SAE#10

Order Code

AMT-HLR-**-10

Almo
Manifold
& Tool

High
Low
& Regen Manifold

Design Version

Size: 16, 25, 32, 40, 50, 63

NOTES:

PILOT-OPERATED
DIRECTIONAL
CONTROL VALVE
CIRCUITS

PILOT-OPERATED DIRECTIONAL CONTROL VALVE CIRCUITS

CUSTOM MANIFOLD

6000 PSI



- Custom manifolds that mount directly to a standard D08/D10 interface or can be designed to accept porting of any size
- Utilizes Almo slip-in cartridge valves instead of a conventional spool
- Poppet valve technology provides:
 - Incredible control
 - Softer shifting
 - Less shock
 - Increased longevity
- Individual pilot controls for each slip-in valve & easily accessible removable orifice plugs allow precise timing for each application

Schematic

Standard
Directional
Schematic

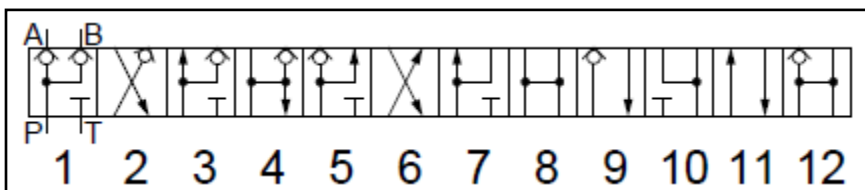
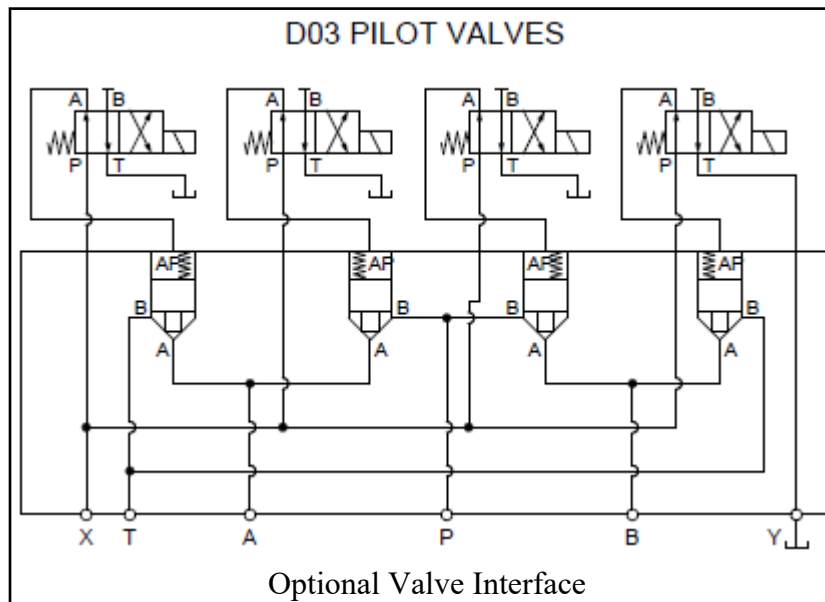

Standard Model: Spool positions shown above can be obtained by energizing or de-energizing the individual solenoid valves

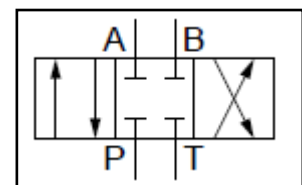

Closed Center Option

HIGH/LOW DIRECTIONAL CONTROL PUMP CIRCUITS

CUSTOM MANIFOLD

5000 PSI

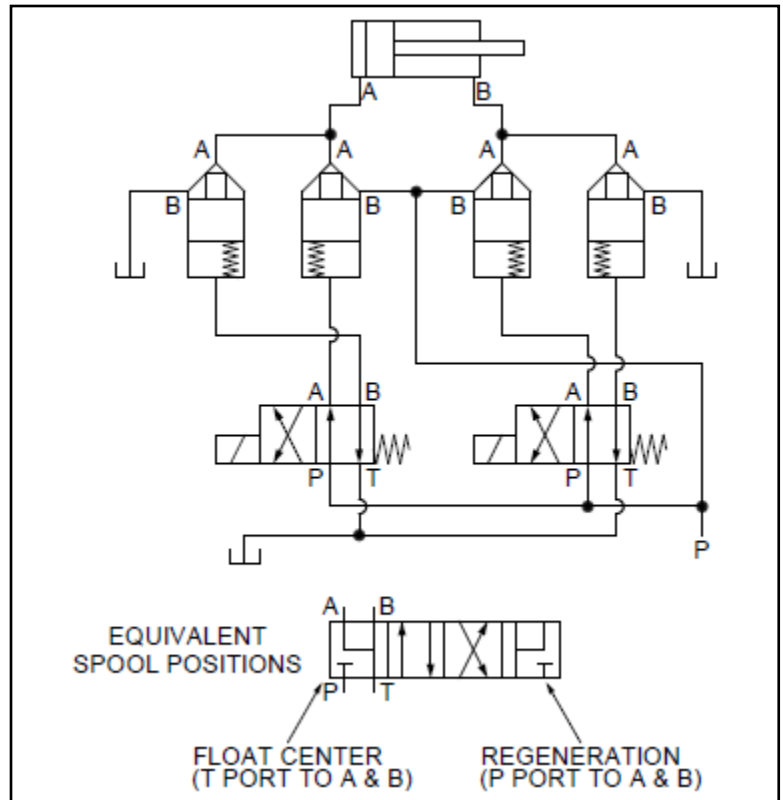

The high flow directional control circuit functions as a 4-way, 4-position valve with extend, retract, & float positions. It utilizes standard slip-in DIN cavities.

The high flow pump control circuit provides an unloading relief function, along with check valves eliminating back flow & one pump overpowering the other.

Pictured above is the combination of a directional circuit and three pump circuits all in one manifold, creating a clean, compact system.

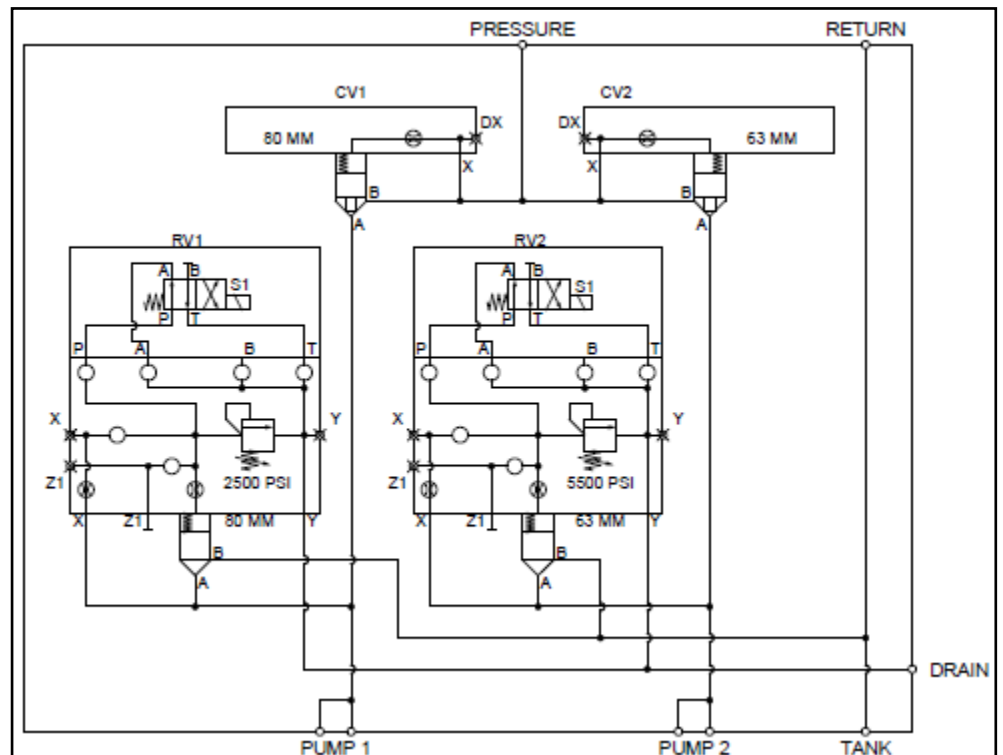

NOTES:

LARGE SPOOL VALVE REPLACEMENTS

LARGE SPOOL VALVE REPLACEMENTS



Olmstead®, Rexroth®, Vickers® | 6000 PSI



Designed to replace aged spool valve technology. Almo offers custom valve packages that mount directly to a large spool valve pattern.

Incorporates Almo slip-in cartridge valve technology.

Poppet valve technology provides:

- Incredible control
- Softer shifting
- Less shock
- Increased longevity
- Easily rebuildable
- Internal or external piloting
- Repeatability

Multiple spool circuit options. We will design around your specifications.



Proportional control version is also available.

Used in these industries:

- Forging
- Extrusion
- Metal forming
- Oil field
- Press
- Die cast
- Plywood
- Stamping

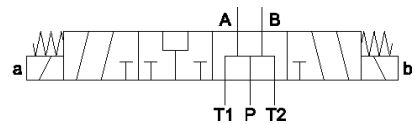
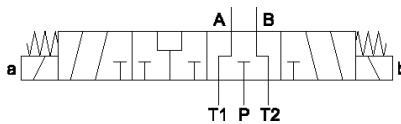
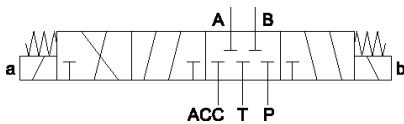

LEGACY INLINE TECHNOLOGY REPLACEMENTS

Denison®, Rexroth®, Vickers®

6000 PSI



Designed to replace discontinued/ unsupported relief valve technology like the DB/DBW Size 52 & 82 or CF Size 16 & 24.

Incorporates Almo slip-in cartridge valve technology.

Poppet valve technology provides:

- Incredible control
- Softer shifting
- Less shock
- Increased longevity
- Easily rebuildable
- Internal or external piloting
- Repeatability

Proportional control version is also available.

Used in these industries:

- Forging
- Extrusion
- Metal forming
- Oil field
- Press
- Die cast
- Wood
- Stamping

Multiple relief circuit options. We will design around your specifications.

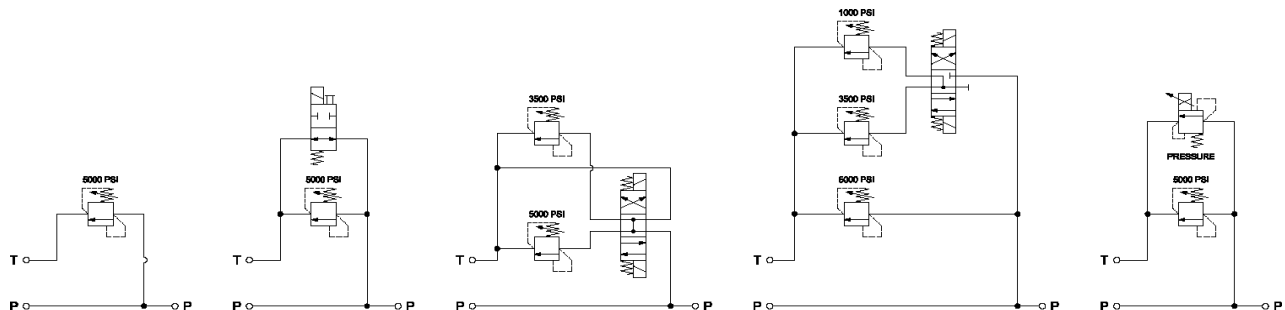

NOTES:

90-DEGREE FLANGE VALVES

90-DEGREE FLANGE HIGH FLOW CHECK VALVE

FLANGE SIZES 1.0" THRU 4.0" | 6000 PSI

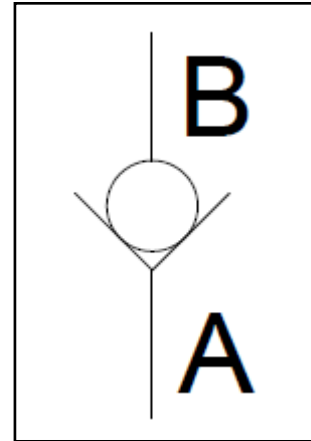

- ✓ Removable NPT orifice
- ✓ SAE O-ring port for access to NPT orifice, gauging, & remote piloting
- ✓ Ships standard with Z1 to A circuit (cover pin in 4-dot pin hole on UCB)
- ✓ Ships standard with a 15 lb. spring unless specified in the model code
- ✓ Reference pages: [10-11](#) (AMT-PCC-**-C), [66-69](#) (UCB block)

Applications

Check Valve

Provides free-flow from A to B & check function from B to A.

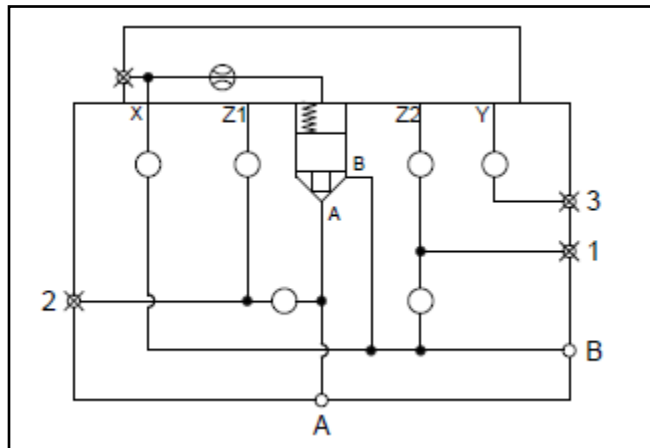

Manual/External Piloting

By blocking the X pilot internally, a separate pilot pressure can be used via the SAE port to manually hold the valve closed. Pilot pressure & spring forces act to close the valve, & forces at A & B act to open the valve.

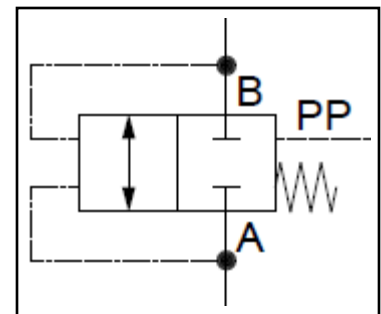
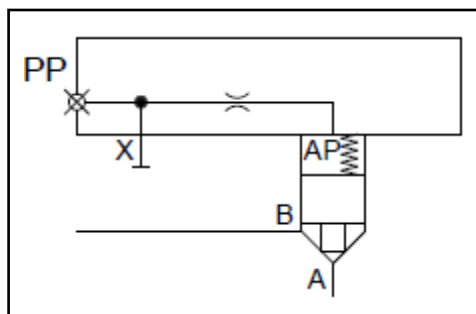

General Layout

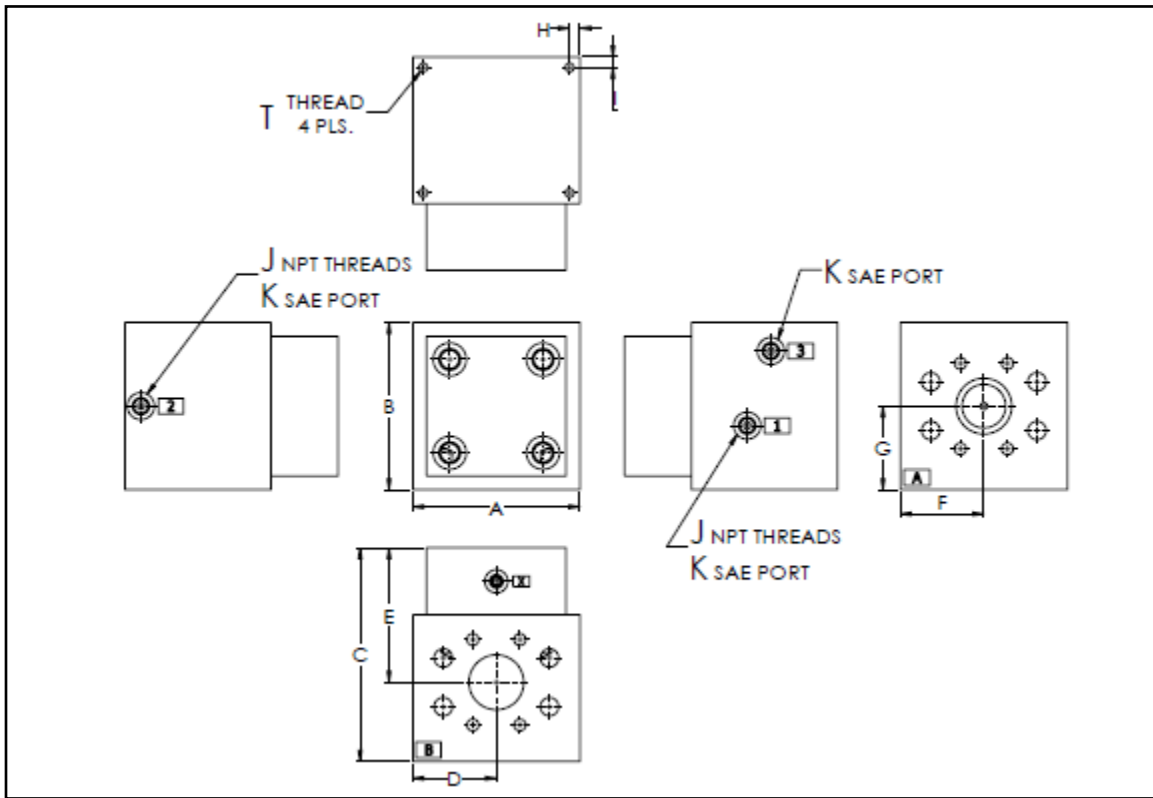

Sizes 1.0" to 4.0"

(4.0" size not shown. Contact Almo for further information)

DIMENSIONAL SPECIFICATIONS IN INCHES

DIN Size	Flange Size	A	B	C	D	E	F	G	H	I	J	K	T
16 mm	1.00	3.25	3.25	4.78	1.63	2.79	1.63	1.63	0.30	0.30	1/16	#4	3/8-16
25 mm	1.25	4.00	4.00	5.50	2.00	3.14	2.00	2.00	0.38	0.38	1/16	#4	3/8-16
32 mm	1.50	5.00	5.00	6.50	2.50	3.98	2.50	2.50	0.38	0.38	1/16	#6	3/8-16
40 mm	2.00	6.00	6.00	7.65	3.00	4.82	3.00	3.00	0.38	0.38	1/16	#6	3/8-16
50 mm	2.50	7.00	7.00	9.00	3.50	5.48	3.50	3.50	0.50	0.50	1/8	#8	1/2-13
63 mm	3.00	9.00	9.00	10.9	4.50	6.91	4.50	5.25	0.63	0.63	1/8	#8	5/8-11
80 mm	4.00	10.0	11.5	13.5	5.00	8.12	5.00	6.00	1.00	1.00	3/8	#10	1-8

Order Code

AMT-9-***-*-CK-**

Almo
Manifold
& Tool

9 = 90-degree

Blank = Ships standard with 15 psi spring
Otherwise, specify: **5**, **30**, **60** psi spring

Size: **100**, **125**, **150**, **200**, **250**, **300**, or **400**

Check **V**alve

For size 400 (80 mm) only: (Ref. pg. [65-66](#))
3 = 3000 Series Flange Option
6 = 6000 Series Flange Option

90-DEGREE FLANGE HIGH FLOW P.O. CHECK VALVE

FLANGE SIZES 1.0" THRU 4.0" | 6000 PSI

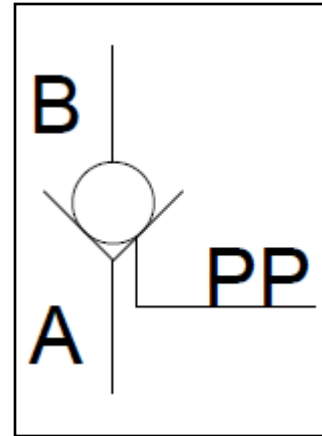

- ✓ Removable orifice plugs
- ✓ 3 to 1 pilot ratio
- ✓ Ships standard with Z1 to A circuit (cover pin in 4-dot pin hole on UCB)
- ✓ Ships standard with a 15 lb. spring unless specified in the model code
- ✓ Reference pages: [12-13](#) (AMT-POCC-**), [66-69](#) (UCB block)

Applications

Pilot-Operated Check Valve

Allows free flow from A to B & provides the check function from B to A by connecting the X pilot to the B port of the logic valve.

To achieve bi-directional flow, just supply Z1 with pilot pressure.

The pilot ratio is 3 to 1.

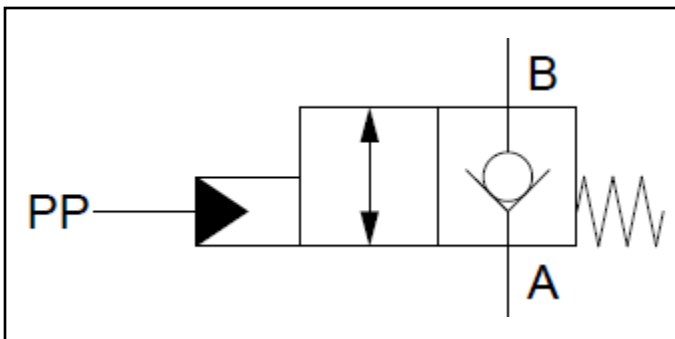
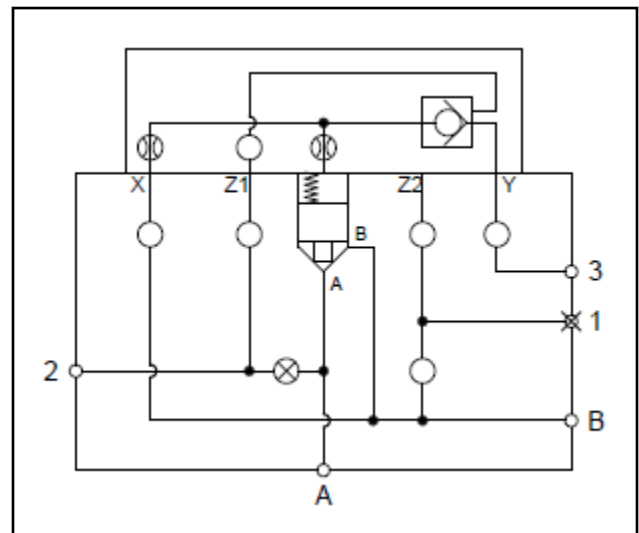

General Layout

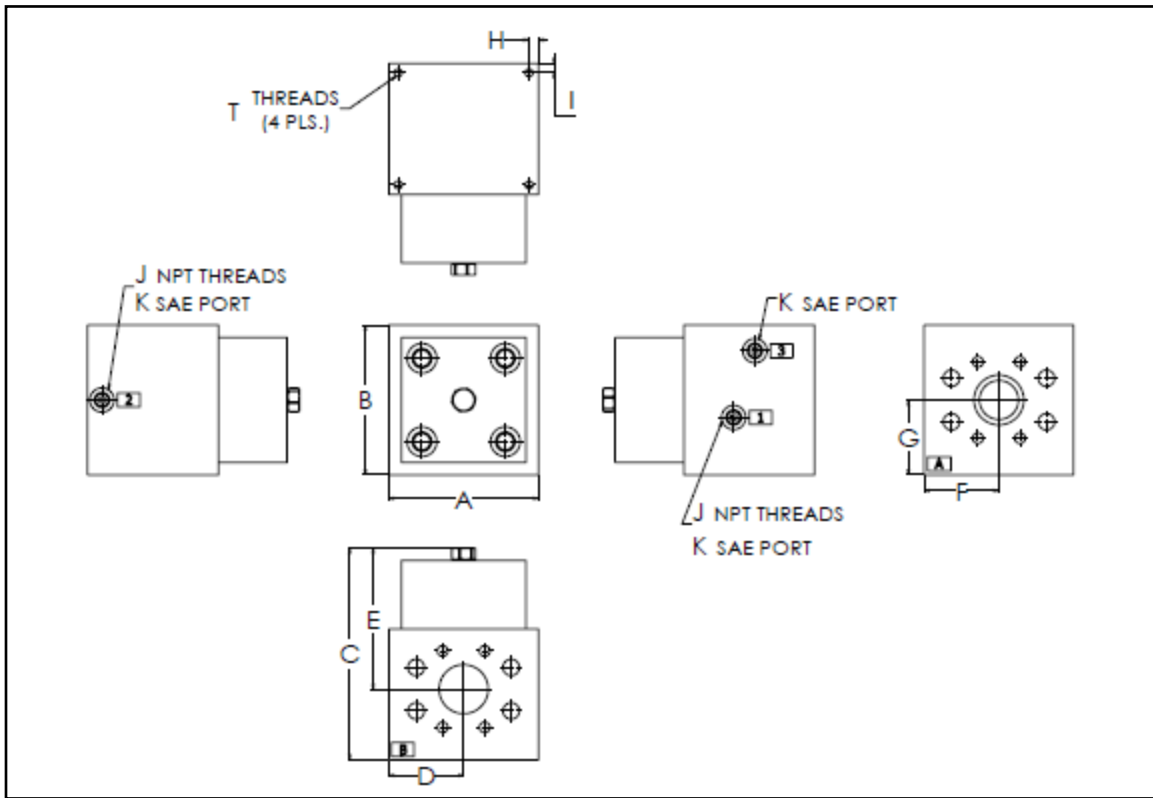

Sizes 1.0" to 4.0"

(4.0" size not shown. Contact Almo for further information)

DIMENSIONAL SPECIFICATIONS IN INCHES

DIN Size	Flange Size	A	B	C	D	E	F	G	H	I	J	K	T
16 mm	1.00	3.25	3.25	6.62	1.63	4.63	1.63	1.63	0.30	0.30	1/16	#4	3/8-16
25 mm	1.25	4.00	4.00	7.24	2.00	4.88	2.00	2.00	0.38	0.38	1/16	#4	3/8-16
32 mm	1.50	5.00	5.00	7.75	2.50	5.22	2.50	2.50	0.38	0.38	1/16	#6	3/8-16
40 mm	2.00	6.00	6.00	8.49	3.00	5.66	3.00	3.00	0.38	0.38	1/16	#6	3/8-16
50 mm	2.50	7.00	7.00	9.49	3.50	5.97	3.50	3.50	0.50	0.50	1/8	#8	1/2-13
63 mm	3.00	9.00	9.00	11.4	4.50	7.40	4.50	5.25	0.63	0.63	1/8	#8	5/8-11
80 mm	4.00	10.0	11.5	14.0	5.00	8.61	5.00	6.00	1.00	1.00	3/8	#10	1-8

Order Code

AMT-9-***-**-PC-ED-**

Almo
Manifold
& Tool

9 = 90-degree

Blank = Ships standard with 15 psi spring
Otherwise, specify: 5, 30, 60 psi spring

Size: 100, 125, 150, 200, 250, 300, or 400

E External Drain

For size 400 (80 mm) only: (Ref. pg. [65-66](#))
3 = 3000 Series Flange Option
6 = 6000 Series Flange Option

Pilot-Operated
Check Valve

90-DEGREE FLANGE HIGH FLOW DUMP VALVE

FLANGE SIZES 1.0" THRU 4.0" | 6000 PSI



- ✓ SAE O-ring ports for access to P & T
- ✓ 1.0" thru 2.0": Ships with standard D03 interface
- ✓ 2.5" thru 4.0": Ships with standard D05 interface. D03 interface available upon request
- ✓ Ships standard with Y to A circuit (cover pin in 3-dot pin hole on UCB)
- ✓ Ships standard with an orifice installed in the P port & a 15 lb. spring unless specified in the model code
- ✓ Reference pages: [14-17](#) (AMT-PDBASH-**), [66-69](#) (UCB block)

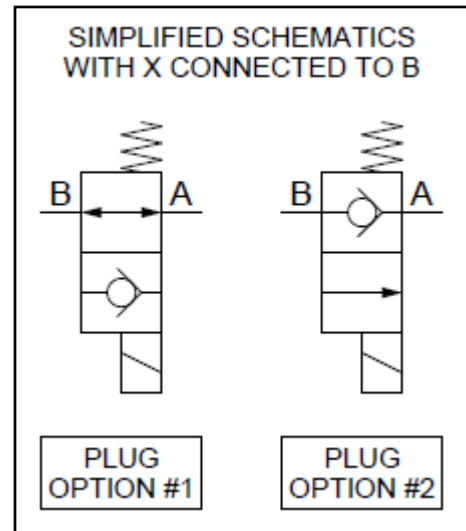

Applications

Dump Valve or ON/OFF Valve

The diagrams below show the two options. The normally open option will allow the valve to dump in the de-energized state. The normally closed option will allow the valve to dump in the energized state.

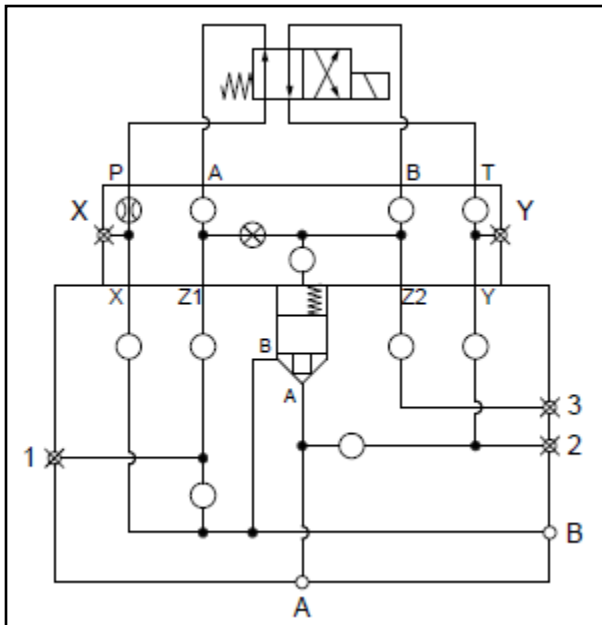

Normally Open

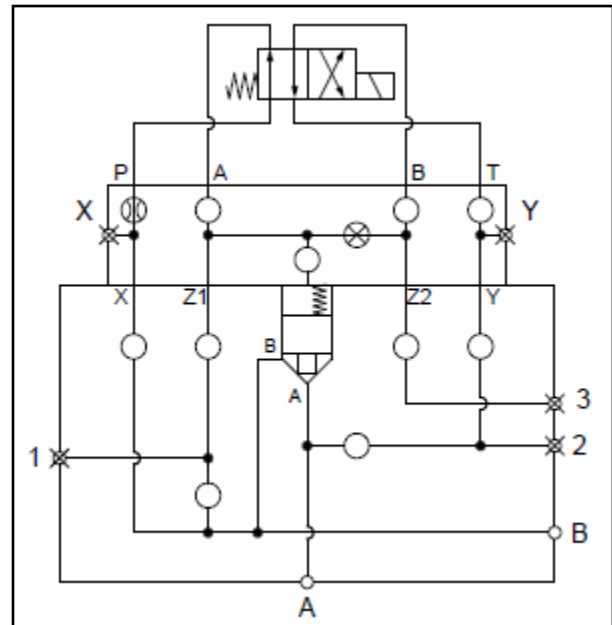

Normally Closed

General Layout

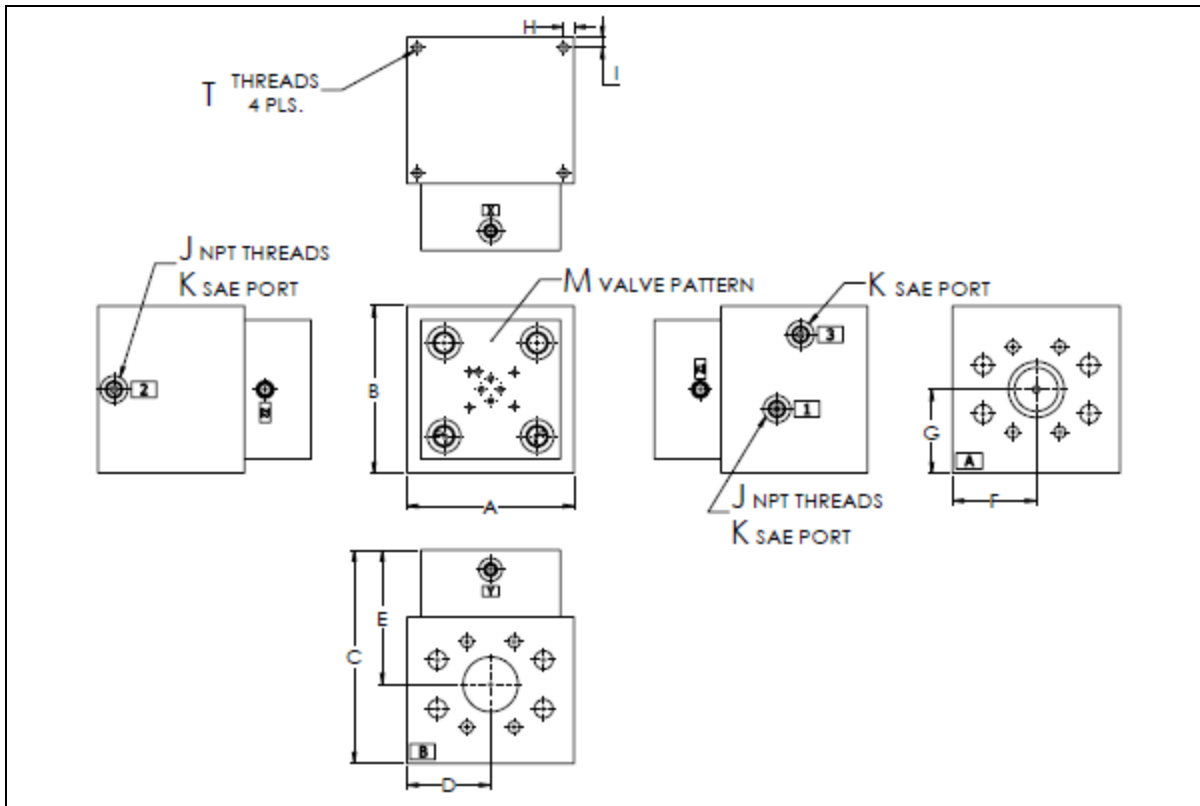

Sizes 1.0" to 4.0"

(4.0" size not shown. Contact Almo for further information)

DIMENSIONAL SPECIFICATIONS IN INCHES

DIN Size	Flange Size	A	B	C	D	E	F	G	H	I	J	K	M	T
16 mm	1.00	3.25	3.25	4.88	1.63	2.89	1.63	1.63	0.30	0.30	1/16	#4	D03	3/8-16
25 mm	1.25	4.00	4.00	6.00	2.00	3.64	2.00	2.00	0.38	0.38	1/16	#4	D03	3/8-16
32 mm	1.50	5.00	5.00	6.50	2.50	3.98	2.50	2.50	0.38	0.38	1/16	#6	D03	3/8-16
40 mm	2.00	6.00	6.00	7.65	3.00	4.82	3.00	3.00	0.38	0.38	1/16	#6	D03	3/8-16
50 mm	2.50	7.00	7.00	9.00	3.50	5.48	3.50	3.50	0.50	0.50	1/8	#8	D05	1/2-13
63 mm	3.00	9.00	9.00	10.9	4.50	6.91	4.50	5.25	0.63	0.63	1/8	#8	D05	5/8-11
80 mm	4.00	10.0	11.5	13.5	5.00	8.12	5.00	6.00	1.00	1.00	3/8	#10	D05	1-8

Order Code

AMT-9-***-**-DV-**-**

Almo
Manifold
& **Tool**

9 = 90-degree

Blank = Ships standard with 15 psi spring
Otherwise, specify: **5**, **30**, **60** psi spring

Size: **100**, **125**, **150**, **200**, **250**, **300**, or **400**

For size 400 (80 mm) only: (Ref. pg. [65-66](#))
3 = 3000 Series Flange Option
6 = 6000 Series Flange Option

NO = Normally open
NC = Normally closed

Dump Valve

90-DEGREE FLANGE BI-DIRECTIONAL VALVE



FLANGE SIZES 1.0" THRU 4.0" | 6000 PSI

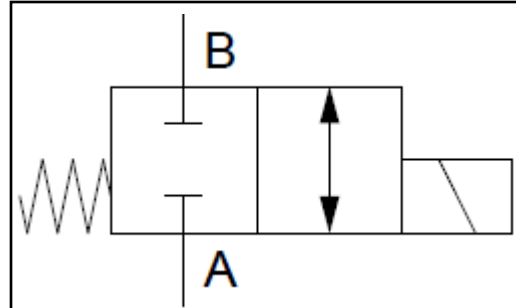

- ✓ Shuttle valve senses the greater of two pressures
- ✓ 1.0" thru 3.0": Ships with standard D03 interface
- ✓ 2.5" thru 3.0": D05 interface available upon request
- ✓ 4.0": Ships with standard D05 interface
- ✓ Ships standard with Z1 to A circuit (cover pin in 4-dot pin hole on UCB)
- ✓ Ships standard with an orifice installed in the P port
- ✓ Ships standard with a 15 lb. spring unless specified in the model code
- ✓ Reference pages: [24-25](#) (AMT-PDSH5-**), [66-69](#) (UCB block)

Applications

On/Off Valve

Will hold the valve closed in one condition & allow the valve to open in the other condition.

Senses the greater of two pressures between the X port & the Z1 port. The X port should be connected to the B port (side of the logic valve), & the Z1 port should be connected to the A port (nose of the logic valve).

By using a standard D03 directional control valve with flow from P to A in the de-energized condition, the shuttle will use the greater pressure to hold the valve closed. Energizing the solenoid vents the pressure above the valve insert to the drain. Flow can travel freely from A to B or from B to A as long as the spring force is overcome.

B to Z2 allows control of additional valve at Port 1.

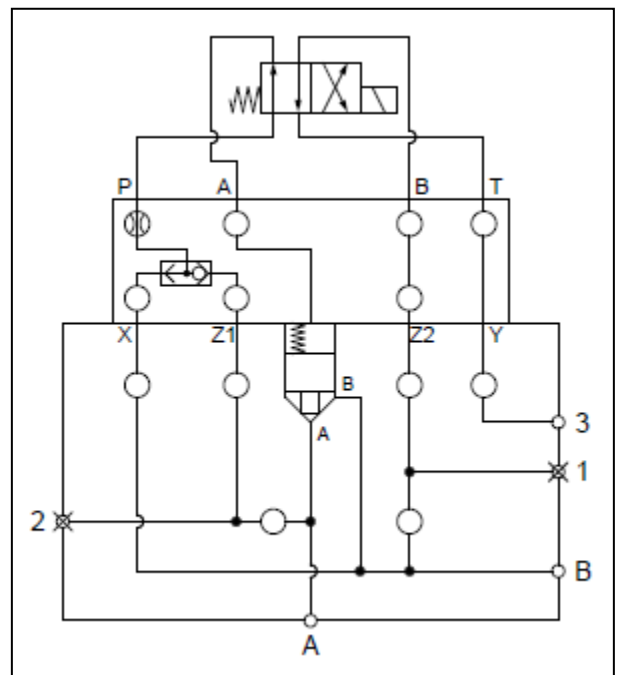

General Layout

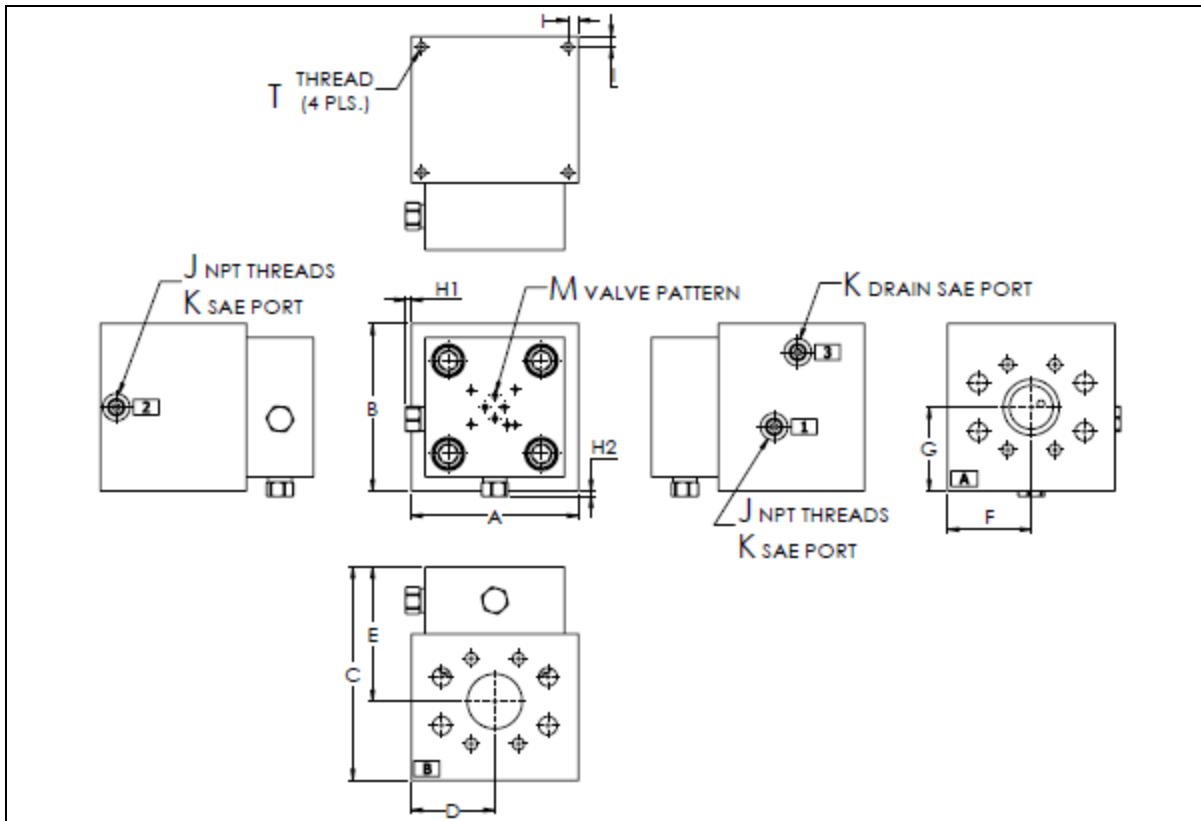

Sizes 1.0" to 4.0"

(4.0" size not shown. Contact Almo for further information)

DIMENSIONAL SPECIFICATIONS IN INCHES

DIN Size	Flange Size	A	B	C	D	E	F	G	H1	H2	I	J	K	M	T
16 mm	1.00	3.25	3.25	5.88	1.63	3.89	1.63	1.63	0.42	0.42	0.30	1/16	#4	D03	3/8-16
25 mm	1.25	4.00	4.00	6.00	2.00	3.64	2.00	2.00	0.53	0.78	0.38	1/16	#4	D03	3/8-16
32 mm	1.50	5.00	5.00	6.50	2.50	3.98	2.50	2.50	0.28	0.28	0.38	1/16	#6	D03	3/8-16
40 mm	2.00	6.00	6.00	7.65	3.00	4.82	3.00	3.00	0.20	0.20	0.38	1/16	#6	D03	3/8-16
50 mm	2.50	7.00	7.00	9.00	3.50	5.48	3.50	3.50	0.00	0.00	0.50	1/8	#8	D03	1/2-13
63 mm	3.00	9.00	9.00	10.9	4.50	6.91	4.50	5.25	0.00	0.00	0.63	1/8	#8	D03	5/8-11
80 mm	4.00	10.0	11.5	13.5	5.00	8.12	5.00	6.00	0.46	0.00	1.00	3/8	#10	D05	1-8

Order Code

AMT-9-***-*-BD-ED-**

Almo
Manifold
& **T**ool

9 = 90-degree

Size: **100**, **125**, **150**, **200**, **250**, **300**, or **400**

For size 400 (80 mm) only: (Ref. pg. 65-66)
3 = 3000 Series Flange Option
6 = 6000 Series Flange Option

Blank = Ships standard with 15 psi spring
Otherwise, specify: **5**, **30**, **60** psi spring

External **D**rain

Bi-**D**irectional

90-DEGREE FLANGE HIGH FLOW RELIEF VALVE

FLANGE SIZES 1.0" THRU 4.0" | 6000 PSI

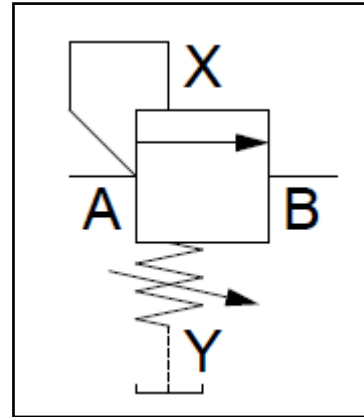

- ✓ Adjustable relief setting from 150 psi to 6000 psi
- ✓ Standard screw adjustment for relief setting
- ✓ Removable orifice plug options
- ✓ SAE O-ring port for gauging
- ✓ Pressure at Y port is directly additive to relief setting
- ✓ Ships standard with X to A circuit (cover pin in 1-dot pin hole on UCB)
- ✓ Ships standard with a 60 lb. spring unless specified in the model code
- ✓ Ships standard 1:1 with Z seal on logic valve
- ✓ Reference pages: [26-27](#) (AMT-PRC-**-S), [66-69](#) (UCB block)

Applications

Relief, Back Pressure, or Sequence Valve

Provides relief function from A to B by connecting the X pilot to the A port of the logic valve. The Y port can be connected to the B port, but a separate drain connection is preferred.

This configuration uses a 1:1 ratio logic valve.

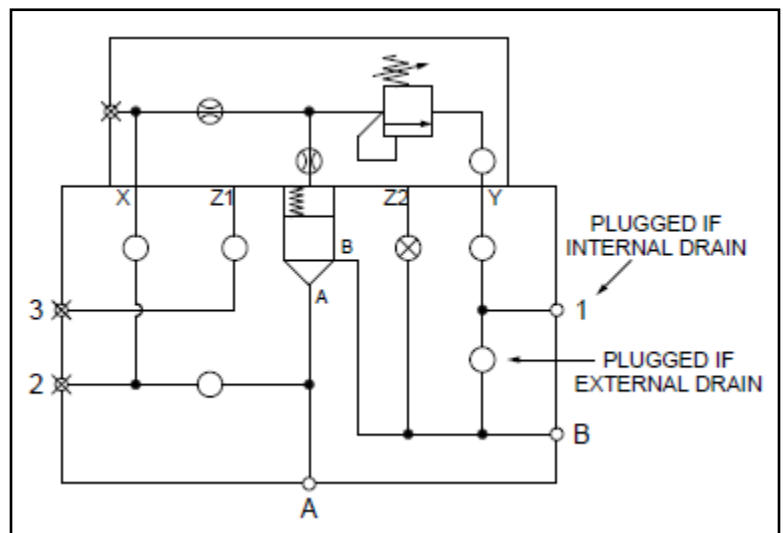

General Layout

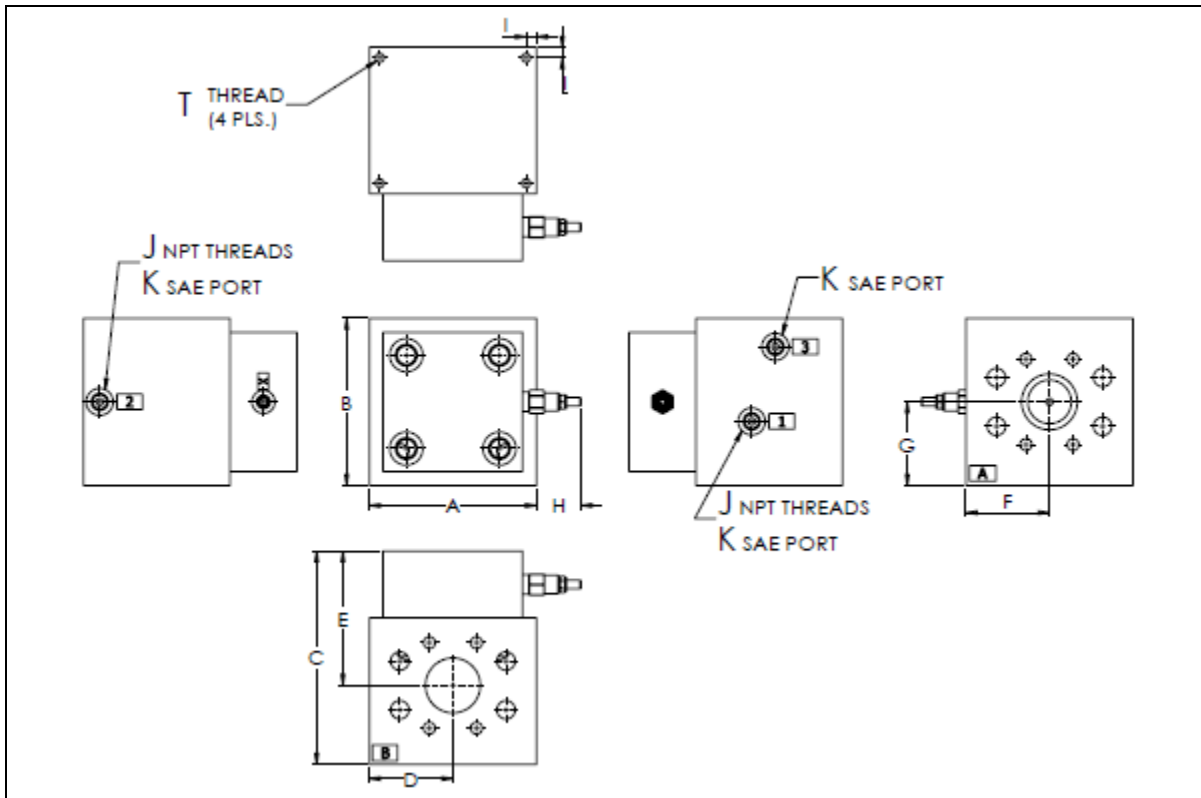

Sizes 1.0" to 4.0"

(4.0" size not shown. Contact Almo for further information)

DIMENSIONAL SPECIFICATIONS IN INCHES

DIN Size	Flange Size	A	B	C	D	E	F	G	H	I	J	K	T
16 mm	1.00	3.25	3.25	4.88	1.63	2.89	1.63	1.63	1.85	0.30	1/16	#4	3/8-16
25 mm	1.25	4.00	4.00	6.00	2.00	3.64	2.00	2.00	1.85	0.38	1/16	#4	3/8-16
32 mm	1.50	5.00	5.00	6.50	2.50	3.98	2.50	2.50	1.60	0.38	1/16	#6	3/8-16
40 mm	2.00	6.00	6.00	7.65	3.00	4.82	3.00	3.00	1.60	0.38	1/16	#6	3/8-16
50 mm	2.50	7.00	7.00	9.00	3.50	5.48	3.50	3.50	1.37	0.50	1/8	#8	1/2-13
63 mm	3.00	9.00	9.00	10.9	4.50	6.91	4.50	5.25	1.10	0.63	1/8	#8	5/8-11
80 mm	4.00	10.0	11.5	13.5	5.00	8.12	5.00	6.00	1.75	1.00	3/8	#10	1-8

Order Code

AMT-9-***-*-RV-**-**

Almo
Manifold
& Tool

9 = 90-degree

Blank = Ships standard with 60 psi spring
Otherwise, specify: 5, 15, 30 psi spring

Size: 100, 125, 150, 200, 250, 300, or 400

For size 400 (80 mm) only: (Ref. pg. [65-66](#))
3 = 3000 Series Flange Option
6 = 6000 Series Flange Option

ID = Internal drain
ED = External drain

Relief Valve

90-DEGREE FLANGE HIGH FLOW LOAD RELIEF VALVE

FLANGE SIZES 1.0" THRU 4.0" | 6000 PSI

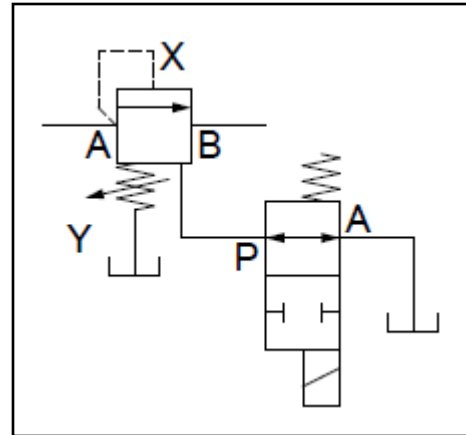
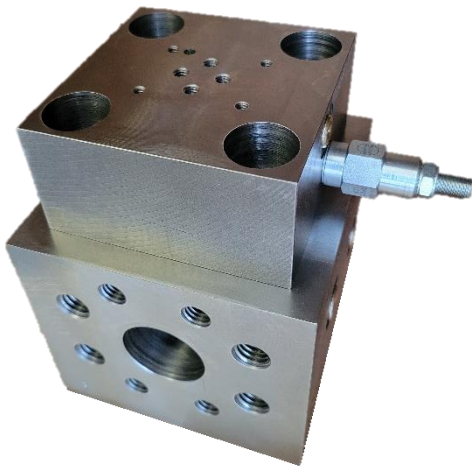

- ✓ Adjustable relief setting from 150 psi to 6000 psi
- ✓ Standard screw adjustment for relief setting. Hand knob available upon request
- ✓ SAE O-ring port for gauging, access to orifices, or remote piloting
- ✓ Pressure at Y port is directly additive to relief setting
- ✓ 16 mm thru 40 mm: Ships standard with D03 interface for loading/venting
- ✓ 50 mm thru 80 mm: Ships standard with D05 interface. 50 mm thru 63 mm: D03 interface available upon request
- ✓ Ships standard with X to A circuit (cover pin in 1-dot pin hole on UCB)
- ✓ Ships standard with a 60 lb. spring unless specified in the model code
- ✓ Ships standard 1:1 with Z seal on logic valve
- ✓ Reference pages: [28-29](#) (AMT-PRC-**-L), [66-69](#) (UCB block)

Applications

Solenoid-Loading Relief Valve

Provides relief function from A to B by connecting the X pilot to the A port of the logic valve.

Using a standard directional control with flow from P to A in the de-energized condition will unload the valve. In the energized state, the system will build pressure until the relief setting is reached. The valve can also be manually vented using the X SAE port.

The Y pilot can be connected to the B port, but a separate drain connection is preferred. This configuration uses a 1:1 ratio valve insert.

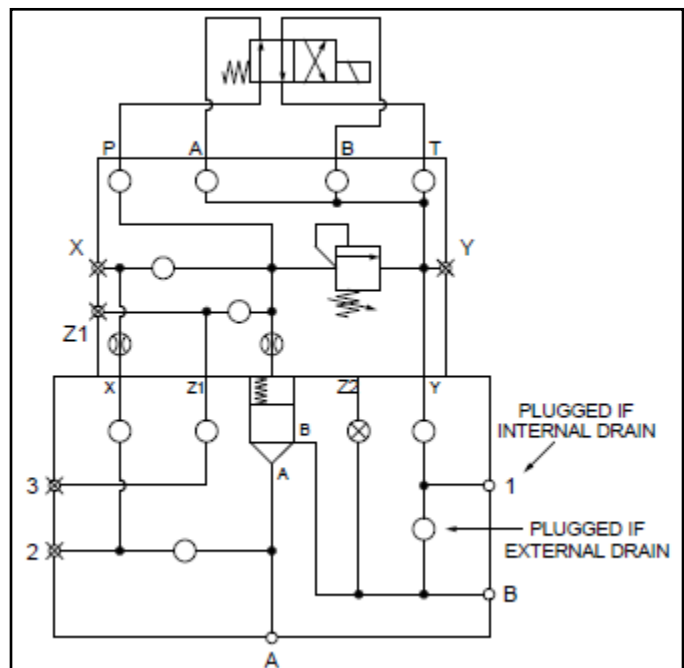

General Layout

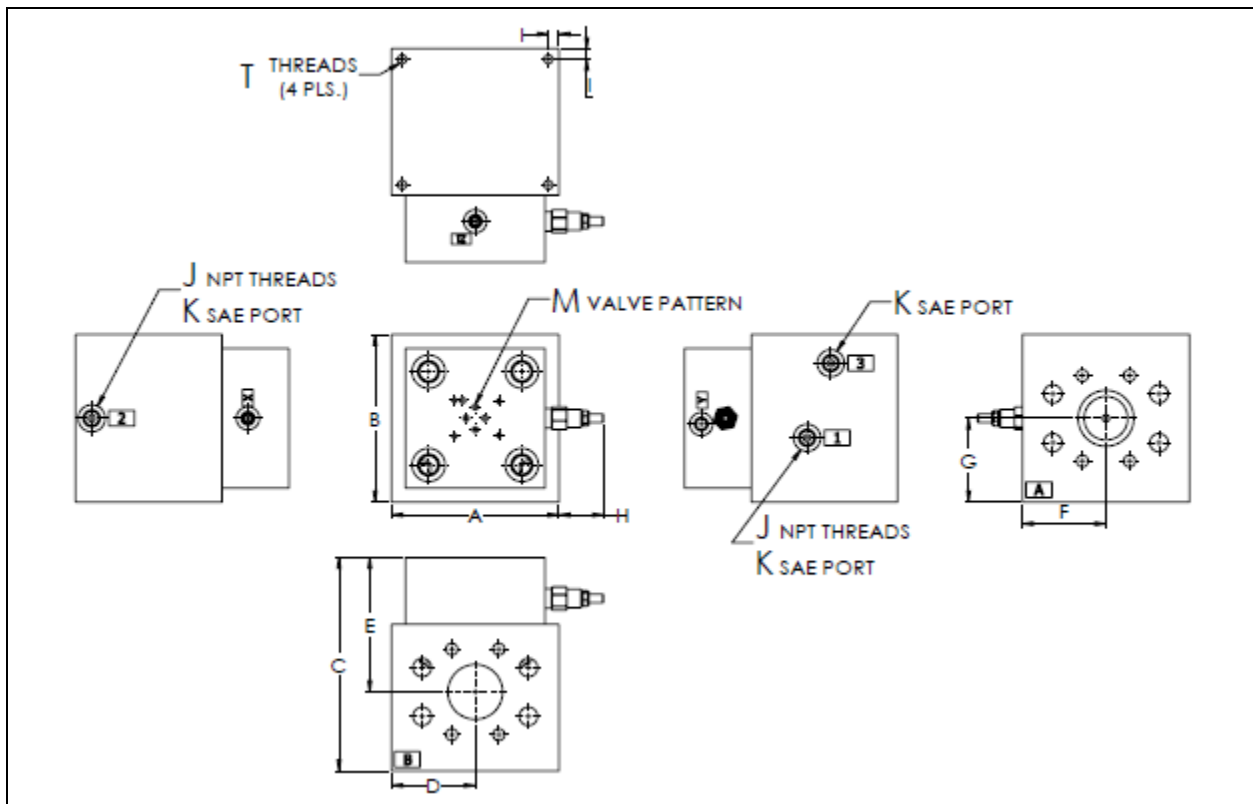

Sizes 1.0" to 4.0"

(4.0" size not shown. Contact Almo for further information)

DIMENSIONAL SPECIFICATIONS IN INCHES

DIN Size	Flange Size	A	B	C	D	E	F	G	H	I	J	K	M	T
16 mm	1.00	3.25	3.25	5.88	1.63	3.89	1.63	1.63	1.85	0.30	1/16	#4	D03	3/8-16
25 mm	1.25	4.00	4.00	6.25	2.00	3.89	2.00	2.00	1.85	0.38	1/16	#4	D03	3/8-16
32 mm	1.50	5.00	5.00	6.50	2.50	3.98	2.50	2.50	1.85	0.38	1/16	#6	D03	3/8-16
40 mm	2.00	6.00	6.00	7.65	3.00	4.82	3.00	3.00	1.60	0.38	1/16	#6	D03	3/8-16
50 mm	2.50	7.00	7.00	9.00	3.50	5.48	3.50	3.50	1.37	0.50	1/8	#8	D05	1/2-13
63 mm	3.00	9.00	9.00	10.9	4.50	6.91	4.50	5.25	1.10	0.63	1/8	#8	D05	5/8-11
80 mm	4.00	10.0	11.5	13.5	5.00	8.12	5.00	6.00	1.71	1.00	3/8	#10	D05	1-8

Order Code

AMT-9-***-*-LR-**-**

Almo
Manifold
& Tool

9 = 90-degree

Size: 100, 125, 150, 200, 250, 300, or 400

For size 400 (80 mm) only: (Ref. pg. [65-66](#))
3 = 3000 Series Flange Option
6 = 6000 Series Flange Option

Blank = Ships standard with 60 psi spring
Otherwise, specify: 5, 15, 30 psi spring

ID = Internal drain
ED = External drain

Load Relief Valve

90-DEGREE FLANGE VOLUME CONTROL VALVE

FLANGE SIZES 1.0" THRU 4.0" | 6000 PSI

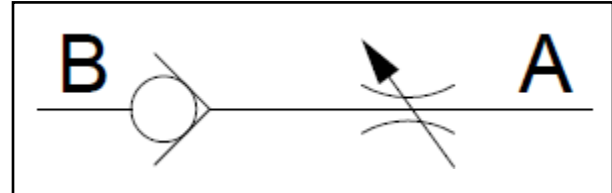

- ✓ Adjustable stroke-limiting cover for decreasing the traveling distance of the logic valve
- ✓ Set screws for locking
- ✓ SAE O-ring port for access to NPT orifice & gauging
- ✓ Removable orifice plug options
- ✓ Ships standard with Z1 to A circuit (cover pin in 4-dot pin hole on UCB)
- ✓ Ships standard with a 15 lb. spring unless specified in the model code
- ✓ Reference pages: [32-33](#) (AMT-PSTK-**), [66-69](#) (UCB block)

Applications

Check/Flow Control Valve

Provides metered flow from A to B (see bottom left image) & the check function from B to A (see bottom right image) by connecting the X pilot to the B port of the logic valve.

Note: To eliminate the check valve function & only use the metering capabilities, connect the X pilot to a drain line instead of connecting the X pilot to the B port.

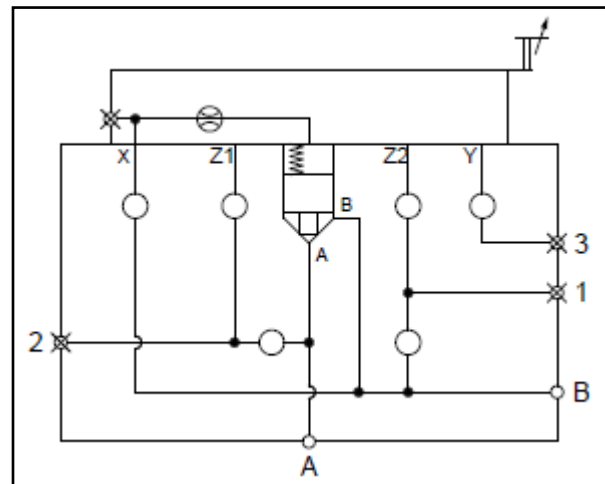

General Layout

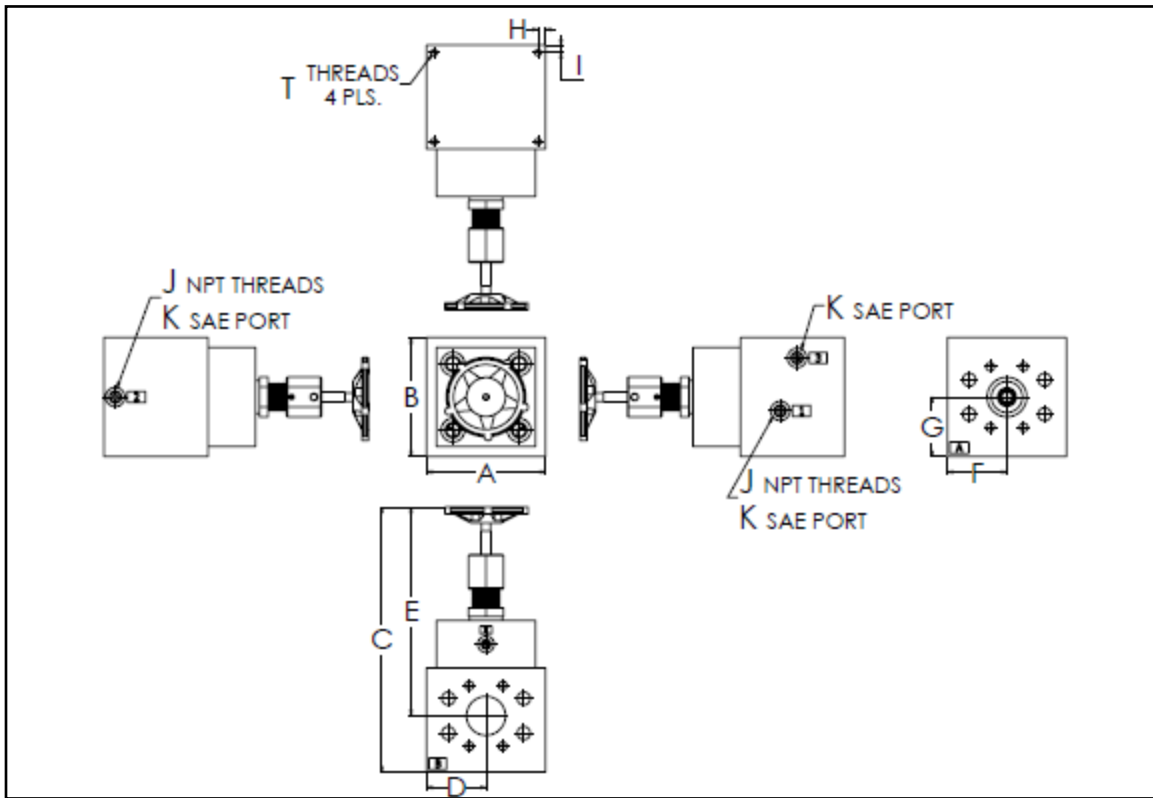

Sizes 1.0" to 4.0"

(4.0" size not shown. Contact Almo for further information)

DIMENSIONAL SPECIFICATIONS IN INCHES

DIN Size	Flange Size	A	B	C	D	E	F	G	H	I	J	K	T
16 mm	1.00	3.25	3.25	7.68	1.63	5.69	1.63	1.63	0.30	0.30	1/16	#4	3/8-16
25 mm	1.25	4.00	4.00	10.0	2.00	7.64	2.00	2.00	0.38	0.38	1/16	#4	3/8-16
32 mm	1.50	5.00	5.00	10.5	2.50	7.98	2.50	2.50	0.38	0.38	1/16	#6	3/8-16
40 mm	2.00	6.00	6.00	13.2	3.00	10.3	3.00	3.00	0.38	0.38	1/16	#6	3/8-16
50 mm	2.50	7.00	7.00	14.4	3.50	10.9	3.50	3.50	0.50	0.50	1/8	#8	1/2-13
63 mm	3.00	9.00	9.00	18.0	4.50	14.0	4.50	5.25	0.63	0.63	1/8	#8	5/8-11
80 mm	4.00	10.0	11.5	22.1	5.00	16.6	5.00	6.00	1.00	1.00	3/8	#10	1-8

Order Code

AMT-9-***-*-VC-**

Almo
Manifold
& Tool

9 = 90-degree

Blank = Ships standard with 15 psi spring
Otherwise, specify: **5**, **30**, **60** psi spring

Size: **100**, **125**, **150**, **200**, **250**, **300**, or **400**

V **C** = Volume Control Valve

For size 400 (80 mm) only: (Ref. pg. 65-66)
3 = 3000 Series Flange Option
6 = 6000 Series Flange Option

ORIFICES

STANDARD ALMO ORIFICE OPTIONS

THREAD SIZES: 1/4-20 UNC, 1/16-27 NPT,
1/8-27 NPT



To order orifices used in the D03 valve pattern, use the following model code:

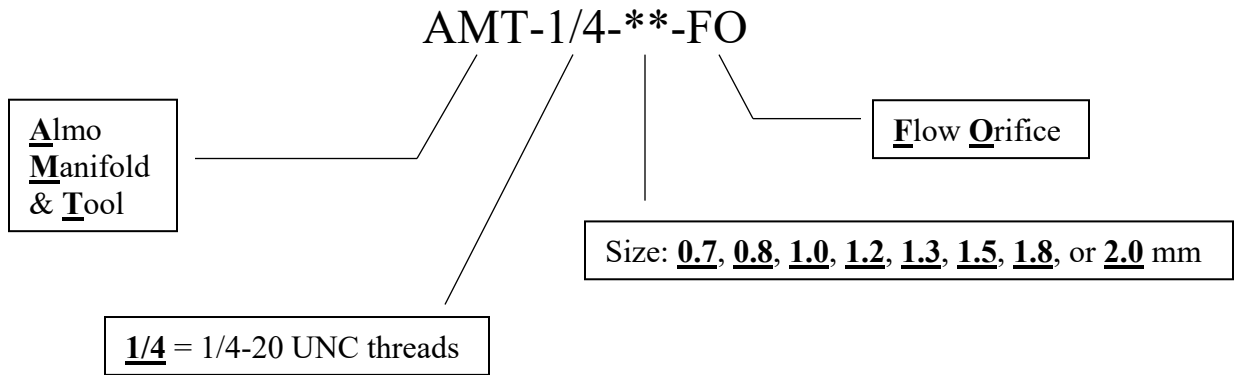

To order orifices used in our AMT-LCV and covers, use the model code below:

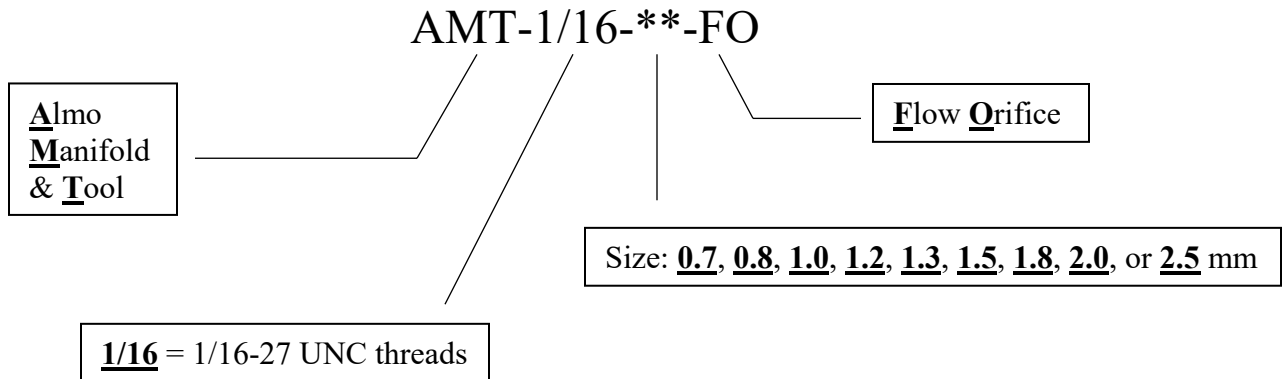

To order orifices used in our covers and the D05 valve pattern, use this model code:

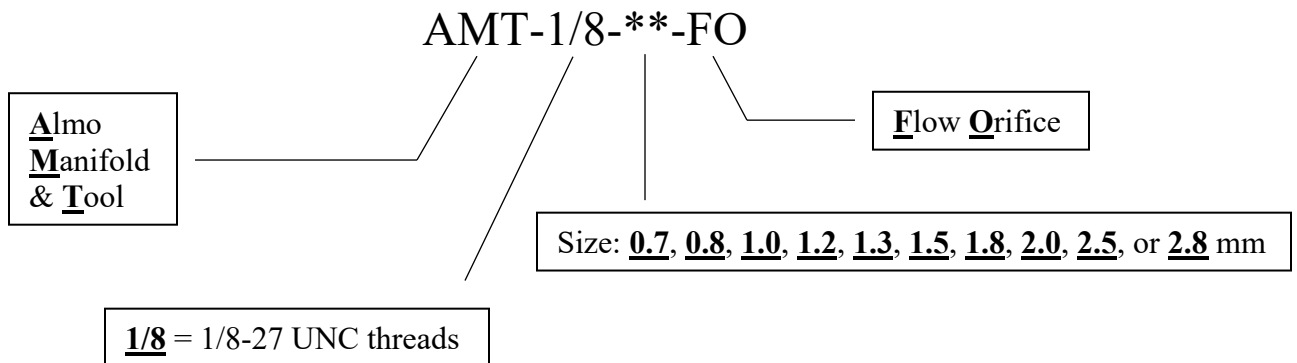

***NOTE:** Please refer to the general layout section of the cover you wish to place an orifice in to determine which size threads you will need for your orifice, The orifice threads are dependent on the cover type, the cover size, and the orifice location in the cover. Custom orifice sizes are available upon request. Please contact the engineering team with any questions.

TECHNICAL INFORMATION

INSTALLATION DIMENSIONS TO MODIFIED DIN 24342 CARTRIDGE VALVES

SIZES 16 MM THRU 100 MM

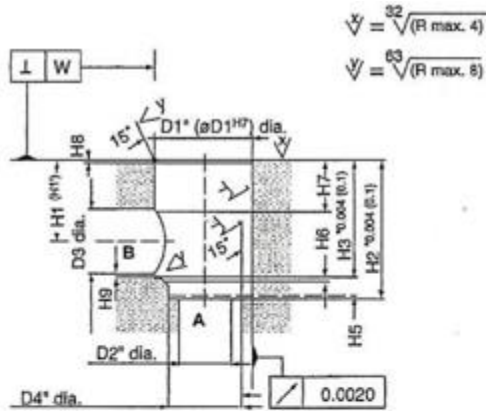

Sizes 16 ... 63

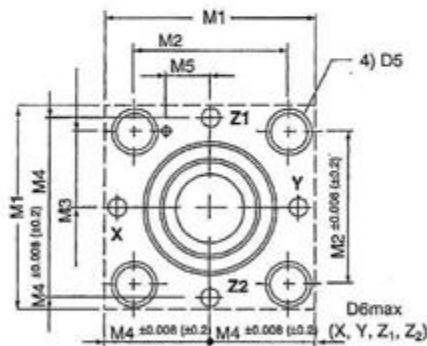

Sizes 80, 100

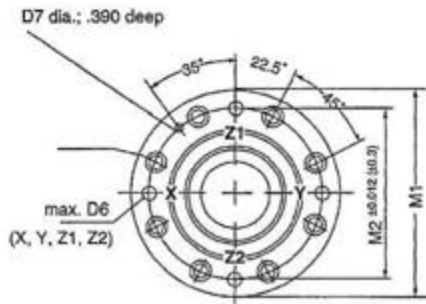

Size Dimension	16mm	25mm	32mm	40mm	50mm	63mm	80mm	100mm
D1 min.	1.2598	1.7717	2.3622	2.9528	3.5433	4.7244	5.7088	7.0868
D1 max.	1.2608	1.7726	2.3633	2.9539	3.5447	4.7258	5.7104	7.0884
D2 max.	.630	.984	1.260	1.575	1.969	2.480	3.150	3.937
D3 min.	.630	.984	1.260	1.575	1.969	2.480	3.150	3.937
D3 max.	.984	1.260	1.575	1.969	2.480	3.150	3.937	4.921
D4 min.	.9843	1.3386	1.7716	2.6653	2.6772	3.5443	4.3312	5.3153
D4 max.	.9851	1.3396	1.7727	2.1665	2.6783	3.5447	4.3326	5.3168
D5 Thread	5/16-18	1/2-13	5/8-11	3/4-10	3/4-10	1-1/4-7	1-8	1-1/8-7
D6 max.	.157	.236	.314	.393	.393	.472	.630	.787
D7 pin hole	.157	.236	.236	.236	.315	.315	.394	.394
H1	1.338	1.732	2.047	2.519	2.834	3.740	5.118	6.103
H1 to D3 max.	1.161	1.594	1.889	2.322	2.578	3.404	4.724	5.591
H2	2.204	2.834	3.346	4.133	4.803	6.103	8.070	9.646
H3	1.692	2.283	2.755	3.425	3.937	5.118	6.882 6.898	8.260 8.276
H5	.433	.472	.511	.590	.669	.787	.984	1.142
H6	.078	.098	.098	.118	.118	.157	1.97	.197
H7	.787	1.181	1.181	1.181	1.377	1.574	1.574	1.969
H8	.079	.098	.098	.118	.157	.157	.197	.197
H9	.059	.059	.059	.118	.118	.118	.177	.177
M1	2.559	3.346	4.016	4.921	5.512	7.087	9.843	11.811
M2	1.811	2.284	2.755	3.347	3.937	4.921	7.874	9.646
M3	.906	1.142	1.377	1.674	1.969	2.461	-	-
M4	.984	1.299	1.614	1.969	2.284	2.063	-	-
M5	.414	.630	.669	.906	1.181	1.496	-	-
W	.0020	.0020	.0039	.0039	.0039	.0079	.0079	.0079

DIN Size	Bolt Thread Size	Torque	Allen Size
16 mm	5/16-18	22 ft-lbs.	1/4"
25 mm	1/2-13	81 ft-lbs.	3/8"
32 mm	5/8-11	210 ft-lbs.	1/2"
40 mm	3/4-10	370 ft-lbs.	5/8"
50 mm	3/4-10	429 ft-lbs.	5/8"
63 mm	1-1/4-7	888 ft-lbs.	7/8"
80 mm	1-8	800 ft-lbs.	3/4"

THE END

